

www.youyeetoo.com	
PROJ	<b>youyeetoo X1</b>
Title	JSL SOC-LPDDR4x CH0
Size A3	Document Number 4
Date:	Saturday, July 15, 2023
Sheet	4 of 39
Rev	A

U1000C  
IC  
INS26356598

BMAP\_REV = 2.0

BJ47 LP4X\_3\_D031DDR\_1\_D063  
BH46 LP4X\_3\_D030DDR\_1\_D062  
BJ49 LP4X\_3\_D029DDR\_1\_D061  
BM51 LP4X\_3\_D028DDR\_1\_D060  
BJ51 LP4X\_3\_D027DDR\_1\_D059  
BL47 LP4X\_3\_D026DDR\_1\_D058  
BL49 LP4X\_3\_D025DDR\_1\_D057  
BM46 LP4X\_3\_D024DDR\_1\_D056  
BP59 LP4X\_3\_D023DDR\_1\_D055  
BP41 LP4X\_3\_D022DDR\_1\_D054  
BP44 LP4X\_3\_D021DDR\_1\_D053  
BM45 LP4X\_3\_D020DDR\_1\_D052  
BP45 LP4X\_3\_D019DDR\_1\_D051  
BM39 LP4X\_3\_D018DDR\_1\_D050  
BM44 LP4X\_3\_D017DDR\_1\_D049  
BM41 LP4X\_3\_D016DDR\_1\_D048  
BC47 LP4X\_3\_D015DDR\_1\_D047  
BC46 LP4X\_3\_D014DDR\_1\_D046  
BD49 LP4X\_3\_D013DDR\_1\_D045  
BF51 LP4X\_3\_D012DDR\_1\_D044  
BC51 LP4X\_3\_D011DDR\_1\_D043  
BF47 LP4X\_3\_D010DDR\_1\_D042  
BF49 LP4X\_3\_D009DDR\_1\_D041  
BF46 LP4X\_3\_D008DDR\_1\_D040  
BH39 LP4X\_3\_D007DDR\_1\_D039  
BH41 LP4X\_3\_D006DDR\_1\_D038  
BH44 LP4X\_3\_D005DDR\_1\_D037  
BF45 LP4X\_3\_D004DDR\_1\_D036  
BF39 LP4X\_3\_D003DDR\_1\_D035  
BF44 LP4X\_3\_D002DDR\_1\_D034  
BF41 LP4X\_3\_D001DDR\_1\_D033  
AG47 LP4X\_3\_D000DDR\_1\_D032  
AG46 LP4X\_2\_D031DDR\_1\_D031  
AG48 LP4X\_2\_D030DDR\_1\_D030  
AH49 LP4X\_2\_D029DDR\_1\_D029  
AK47 LP4X\_2\_D028DDR\_1\_D028  
AG51 LP4X\_2\_D027DDR\_1\_D027  
AK51 LP4X\_2\_D026DDR\_1\_D026  
AK46 LP4X\_2\_D025DDR\_1\_D025  
AK49 LP4X\_2\_D024DDR\_1\_D024  
AK41 LP4X\_2\_D023DDR\_1\_D023  
AK39 LP4X\_2\_D022DDR\_1\_D022  
AK44 LP4X\_2\_D021DDR\_1\_D021  
AH44 LP4X\_2\_D020DDR\_1\_D020  
AK45 LP4X\_2\_D019DDR\_1\_D019  
AH41 LP4X\_2\_D018DDR\_1\_D018  
AH46 LP4X\_2\_D017DDR\_1\_D017  
AH59 LP4X\_2\_D016DDR\_1\_D016  
AB47 LP4X\_2\_D015DDR\_1\_D015  
AB46 LP4X\_2\_D014DDR\_1\_D014  
AB49 LP4X\_2\_D013DDR\_1\_D013  
AD47 LP4X\_2\_D012DDR\_1\_D012  
AB51 LP4X\_2\_D011DDR\_1\_D011  
AE51 LP4X\_2\_D010DDR\_1\_D010  
AE59 LP4X\_2\_D009DDR\_1\_D009  
AE46 LP4X\_2\_D008DDR\_1\_D008  
AD39 LP4X\_2\_D007DDR\_1\_D007  
AD41 LP4X\_2\_D006DDR\_1\_D006  
AD44 LP4X\_2\_D005DDR\_1\_D005  
AB45 LP4X\_2\_D004DDR\_1\_D004  
AD46 LP4X\_2\_D003DDR\_1\_D003  
AB44 LP4X\_2\_D002DDR\_1\_D002  
AB39 LP4X\_2\_D001DDR\_1\_D001  
AB41 LP4X\_2\_D000DDR\_1\_D000

3 OF 19

NA\_72049

LP4X\_3\_CLK\_DNDDR\_1\_CLK1\_DN AV51  
LP4X\_3\_CLK\_DPDDR\_1\_CLK1\_DP AV49  
LP4X\_2\_CLK\_DNDDR\_1\_CLK0\_DN AV47  
LP4X\_2\_CLK\_DPDDR\_1\_CLK0\_DP AV48  
LP4X\_2\_CKE1 AY41  
LP4X\_2\_CKE0DDR\_1\_CKE0 AY42  
LP4X\_3\_CKE1DDR\_1\_CKE1 AY45  
LP4X\_3\_CKE0 BB44  
LP4X\_2\_CS1 AY50  
LP4X\_2\_CS0DDR\_1\_CS0\_N AW48  
LP4X\_3\_CS1DDR\_1\_CS1\_N BA51  
LP4X\_3\_CS0 AY47  
LP4X\_3\_CA0DDR\_1\_MA13 AT51  
LP4X\_3\_CA0DDR\_1\_BA0 AN51  
DDR\_1\_BG1 AP44  
LP4X\_2\_CASDDR\_1\_BG0 AT45  
LP4X\_3\_CA3DDR\_1\_MA16\_RAS\_N AR49  
LP4X\_3\_CA1DDR\_1\_MA16\_CAS\_N BA49  
LP4X\_3\_CA2DDR\_1\_MA14\_WE\_N AP50  
DDR\_1\_BA1 AN47  
DDR\_1\_MA12 AP45  
DDR\_1\_MA11 AP42  
DDR\_1\_MA10 AT48  
LP4X\_2\_CA1DDR\_1\_MA09 AT42  
LP4X\_2\_CA0DDR\_1\_MA08 AT41  
LP4X\_2\_CA4DDR\_1\_MA07 AT39  
LP4X\_2\_CA2DDR\_1\_MA06 AT44  
LP4X\_2\_CA0DDR\_1\_MA05 AP41  
DDR\_1\_MA04 AY44  
DDR\_1\_MA03 BB42  
LP4X\_3\_CASDDR\_1\_MA02 AR47  
DDR\_1\_MA01 AN49  
DDR\_1\_MA00 AP48  
DDR\_1\_ODT1 AM48  
DDR\_1\_ODT0 BA48  
LP4X\_3\_D0S3\_DPDDR\_1\_D0S7\_DP BK48  
LP4X\_3\_D0S3\_DNDDR\_1\_D0S7\_DN BK50  
LP4X\_3\_D0S2\_DPDDR\_1\_D0S6\_DP BP42  
LP4X\_3\_D0S2\_DNDDR\_1\_D0S6\_DN BM42  
LP4X\_3\_D0S1\_DPDDR\_1\_D0S5\_DP BE48  
LP4X\_3\_D0S1\_DNDDR\_1\_D0S5\_DN BE50  
LP4X\_3\_D0S0\_DPDDR\_1\_D0S4\_DP BF42  
LP4X\_3\_D0S0\_DNDDR\_1\_D0S4\_DN BF42  
LP4X\_2\_D0S3\_DPDDR\_1\_D0S3\_DP AJ48  
LP4X\_2\_D0S3\_DNDDR\_1\_D0S3\_DN AJ50  
LP4X\_2\_D0S2\_DPDDR\_1\_D0S2\_DP AH42  
LP4X\_2\_D0S2\_DNDDR\_1\_D0S2\_DN AK42  
LP4X\_2\_D0S1\_DPDDR\_1\_D0S1\_DP AC48  
LP4X\_2\_D0S1\_DNDDR\_1\_D0S1\_DN AC50  
LP4X\_2\_D0S0\_DPDDR\_1\_D0S0\_DP AD42  
LP4X\_2\_D0S0\_DNDDR\_1\_D0S0\_DN AB42  
DDR\_1\_PAR BB45  
DDR\_1\_ACT\_N AP39  
DDR\_1\_ALERT\_N AY39

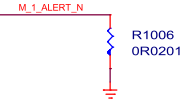

youyeetoo		www.youyeetoo.com	
PROJ	youyeetoo X1		
Title	JSL SOC-LPDDR4x CH1		
Size	Document Number	Rev A	
A3	4	A	
Date:	Saturday, July 15, 2023	Sheet	5 of 39

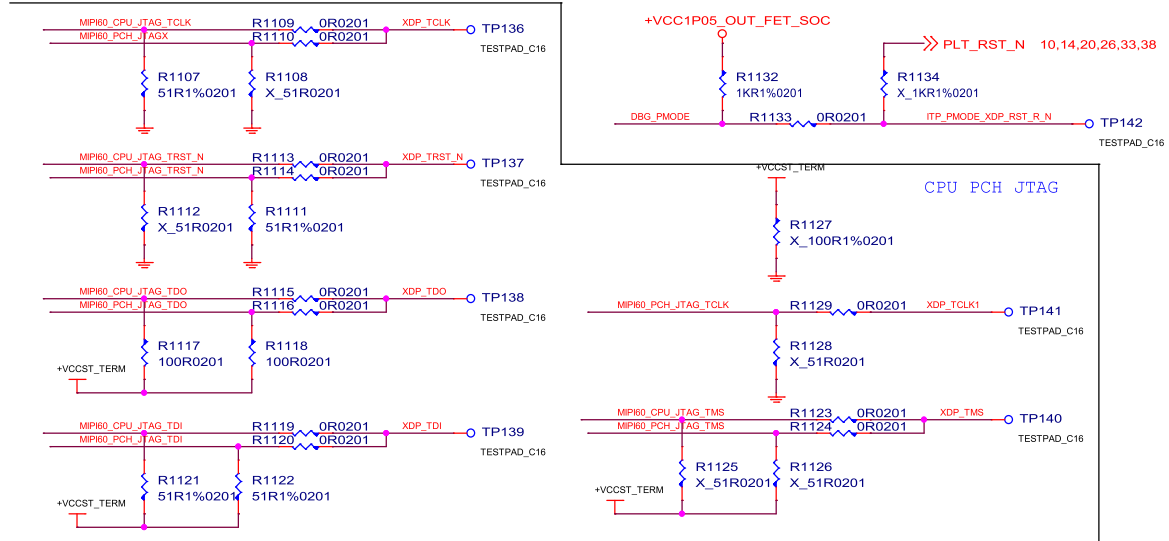
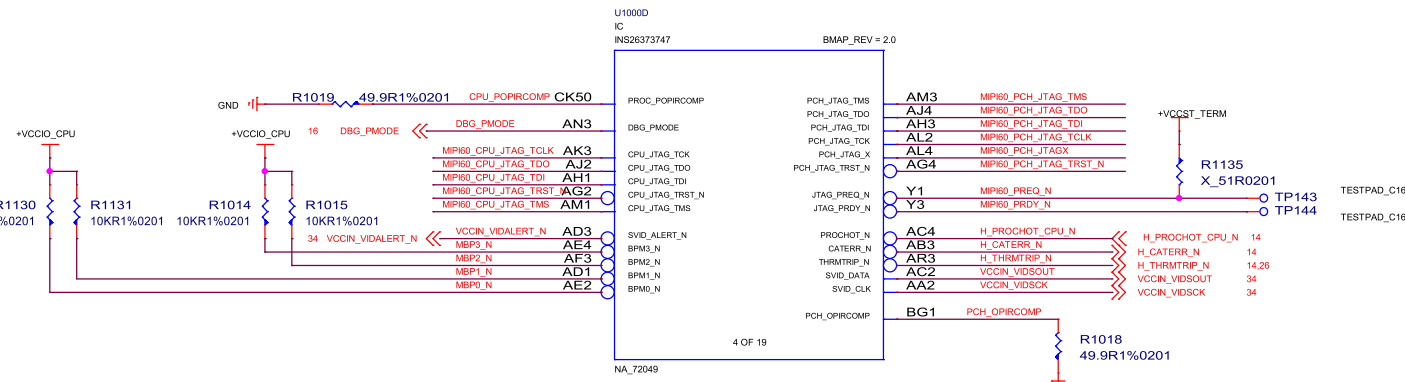
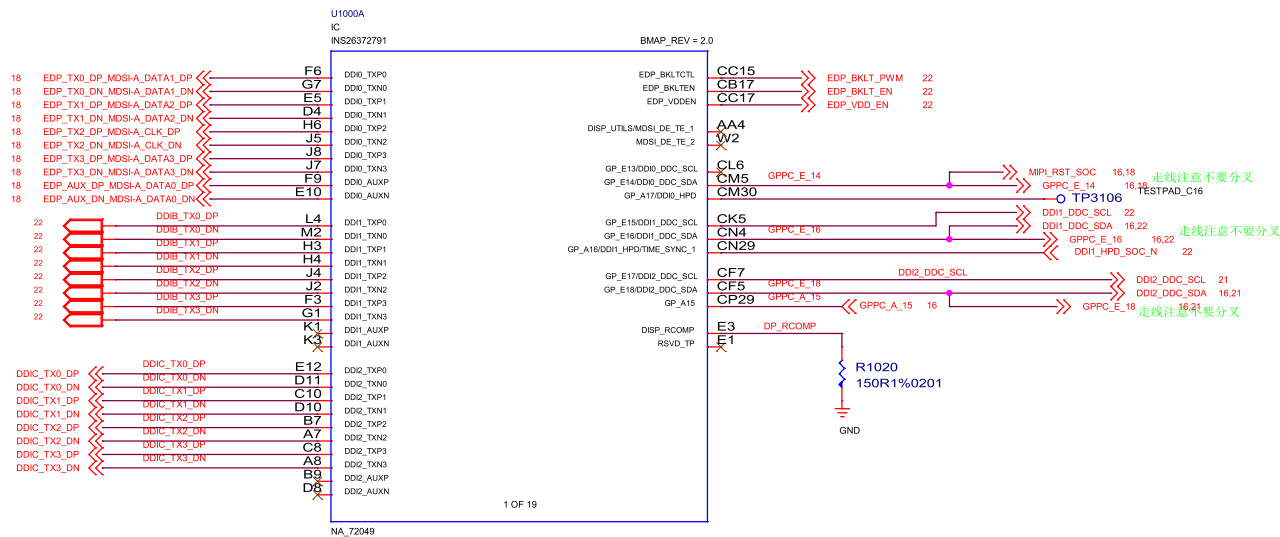

www.youyeetoo.com	
PROJ	<b>youyeetoo X1</b>
Title	JSL SOC-DISPLAY&CPU MI_JTAG
Size A3	Document Number 6
Date: Saturday, July 15, 2023	Sheet 6 of 39

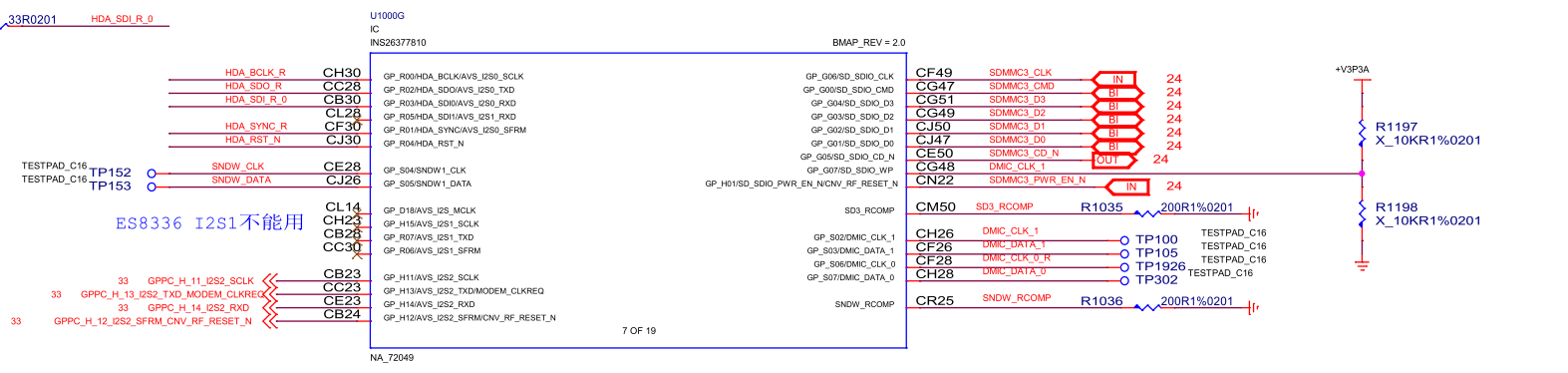
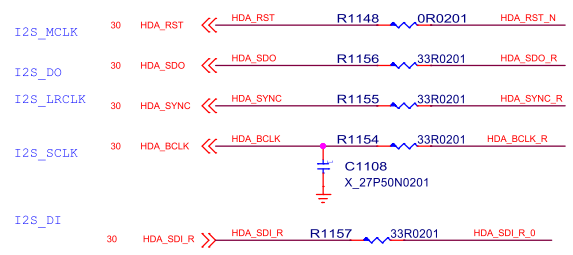
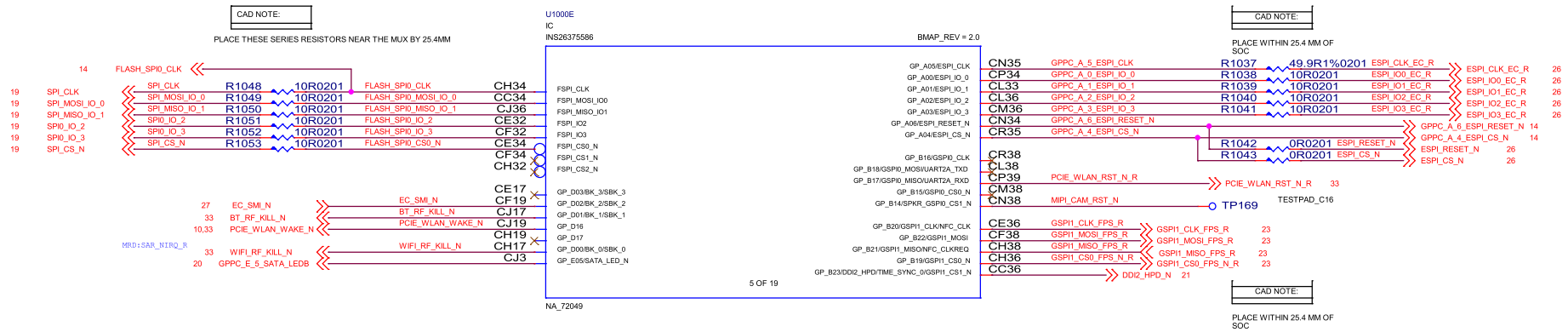

www.youyeetoo.com

**PROJ youyeetoo X1**

Title JSL SOC-SPI-AUDIO

Size A3	Document Number 7	Rev A
---------	-------------------	-------

Date: Saturday, July 15, 2023 Sheet 7 of 39

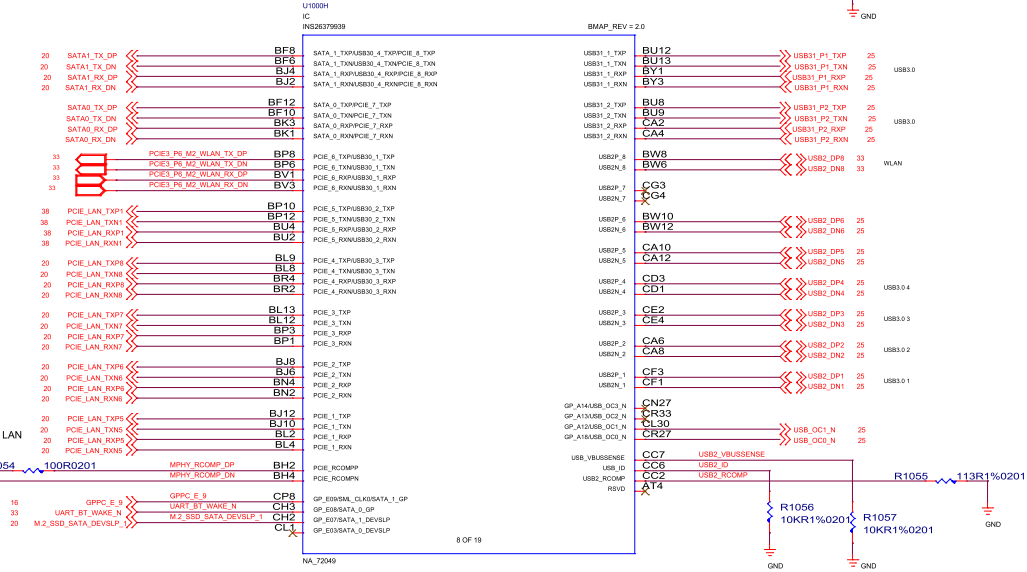
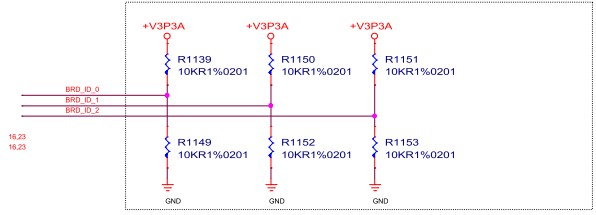
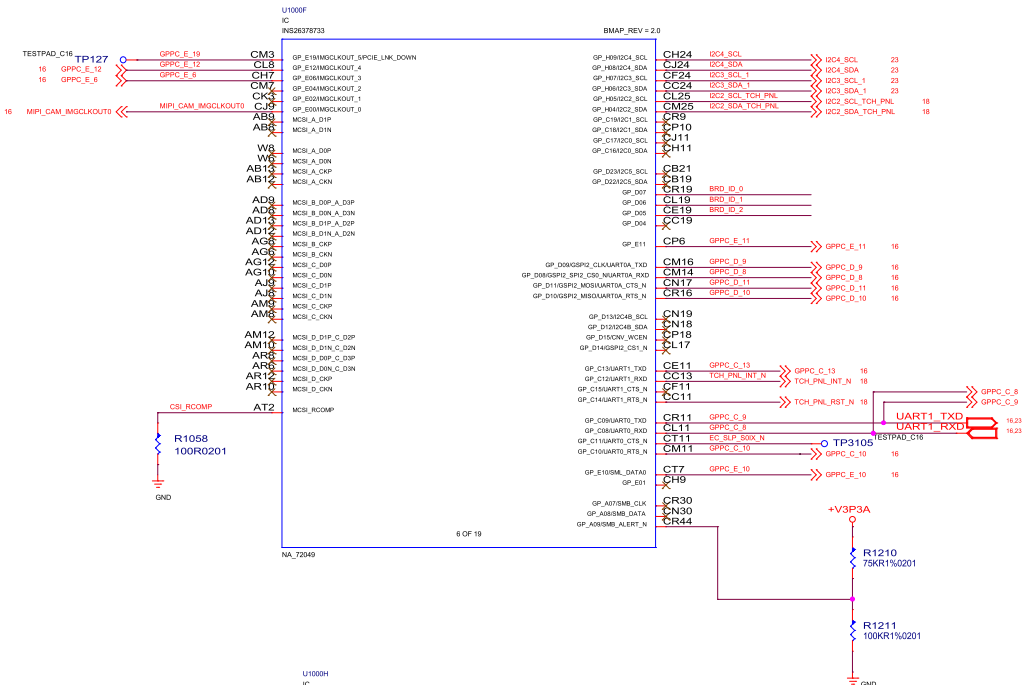

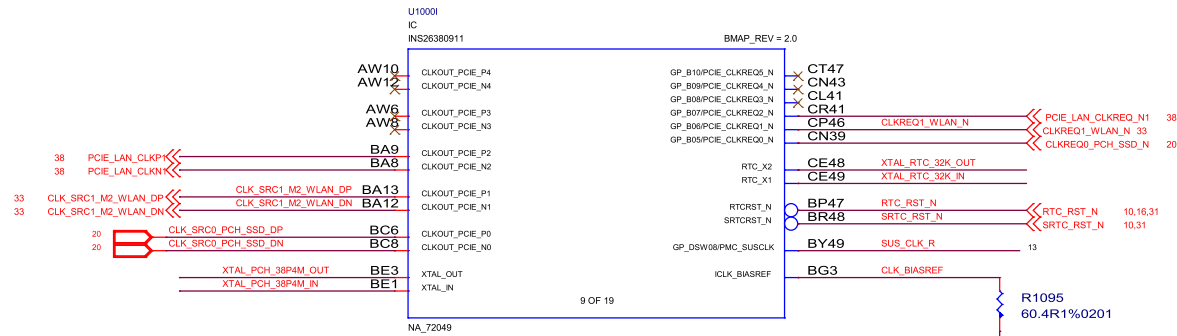

CAD NOTE:

PLACE R5711 & R189 WITHIN 50.8MM OF SOC

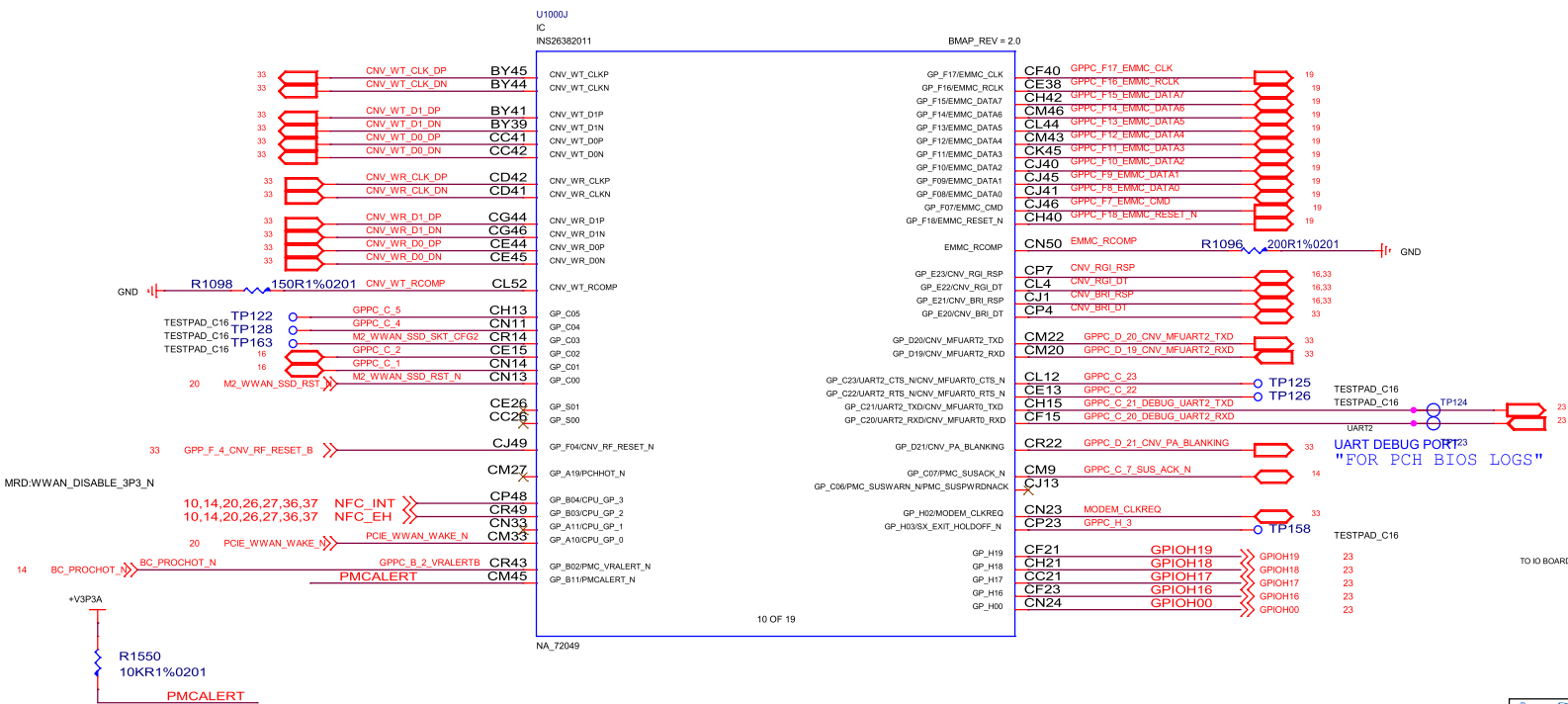
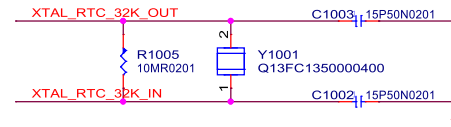
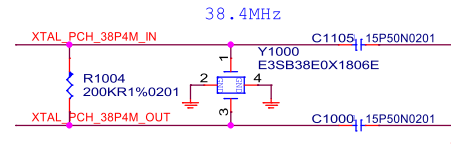
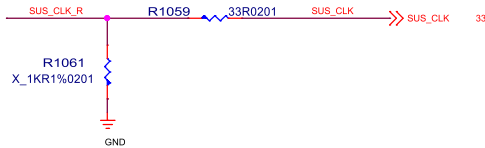

NA\_72049

10 OF 19

TO IO BOARD

UART2  
"FOR PCH BIOS LOGS"

www.youyeetoo.com	
PROJ	<b>youyeetoo X1</b>
Title	JSL SOC-CLOCKS-CNV1
Size A3	Document Number 9
Date:	Saturday, July 15, 2023
Sheet	9 of 39
Rev	A

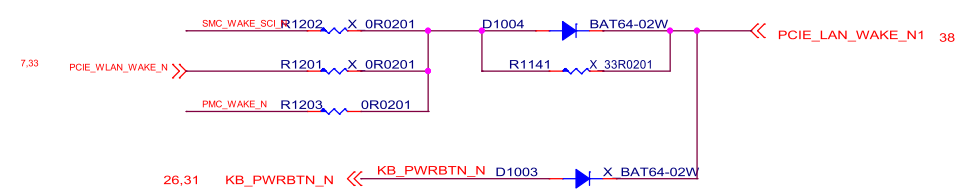
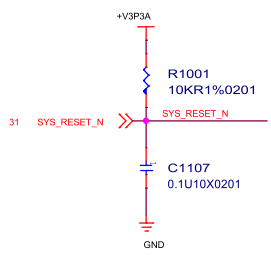
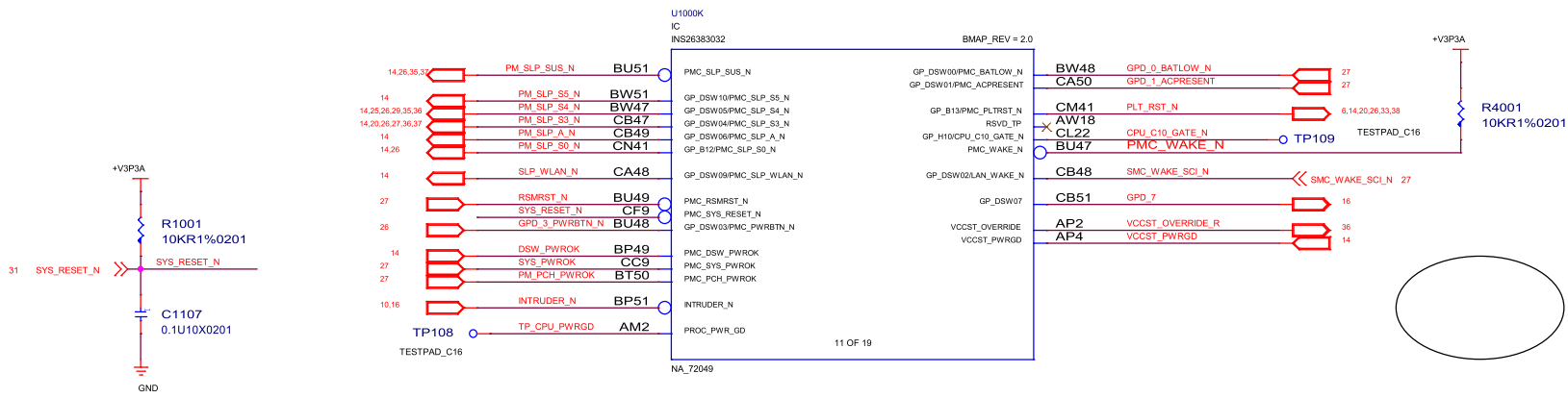

**SPI VCCSSIO VOLTAGE CONFIGURATION**

0 = SPI OPERATION VOLTAGE IS 3.3V (10 KOHM PULL-DOWN TO GND)

1 = SPI OPERATION VOLTAGE IS 1.8V (1 MOHM PULL-UP TO VCCRTC)

NO INTERNAL PU/PD

SAMPLING DSW\_PWROK

**RTC Circuit**

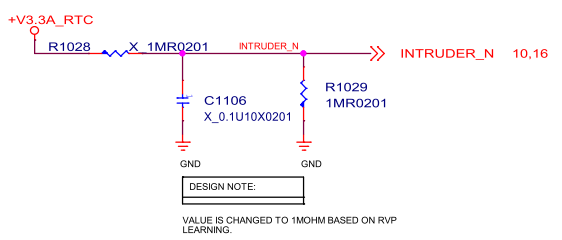
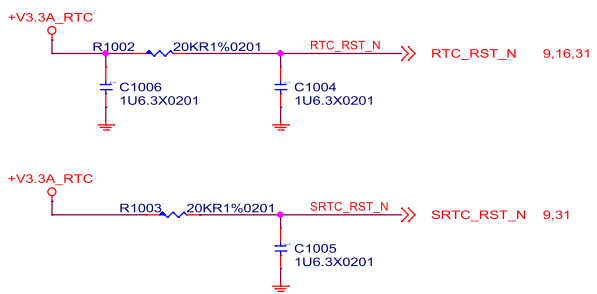

DESIGN NOTE:

VALUE IS CHANGED TO 1MOHM BASED ON RVP LEARNING.

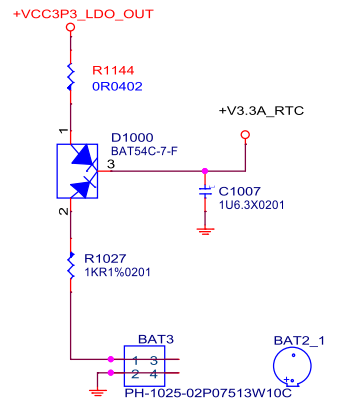

www.youyeetoo.com	
PROJ	<b>youyeetoo X1</b>
Title	JSL SOC-POWER-RTC AND SRTC
Size A3	Document Number 9
Date:	Saturday, July 15, 2023
Sheet	10 of 39
Rev	A

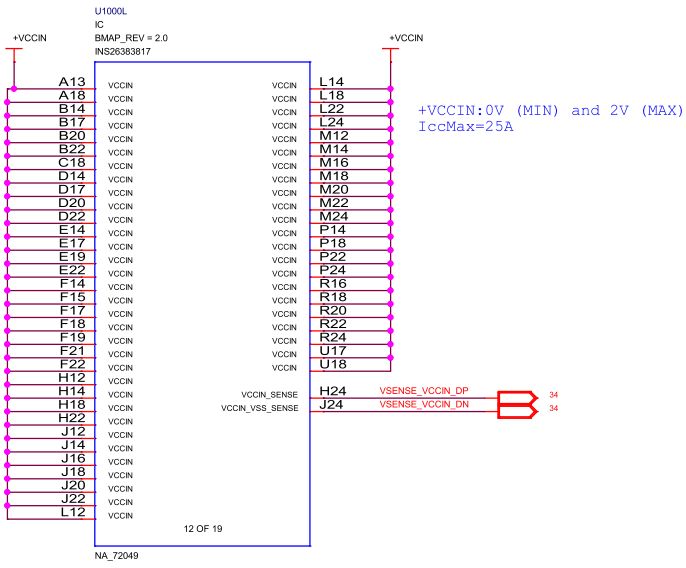

+VCCIN:0V (MIN) and 2V (MAX)  
IccMax=25A

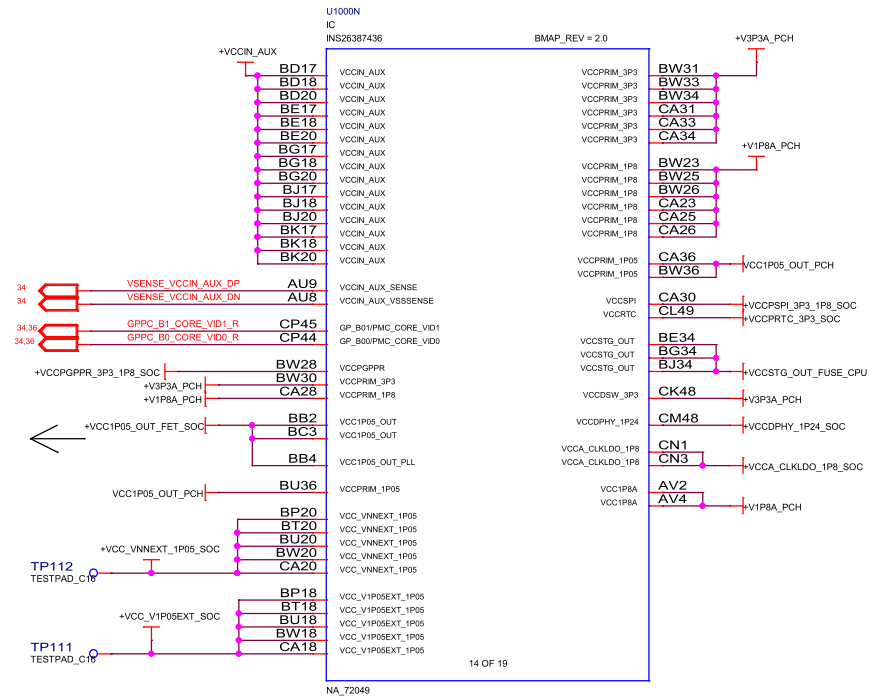
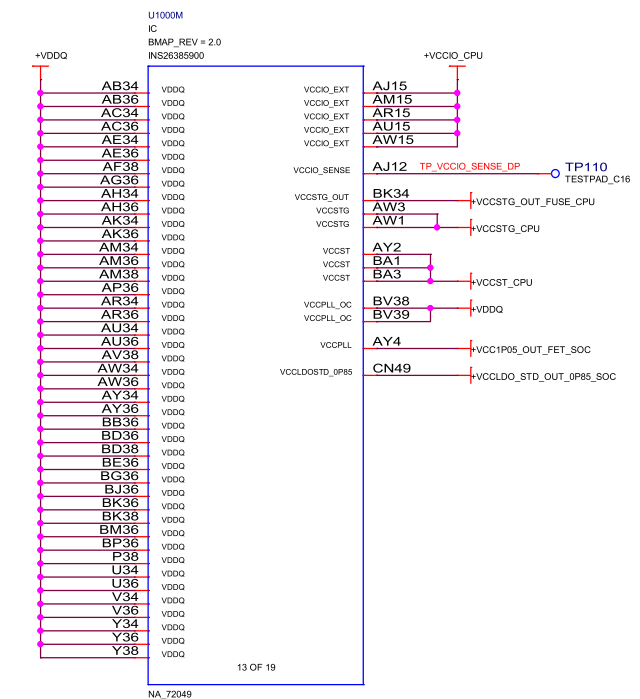
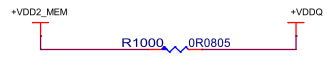
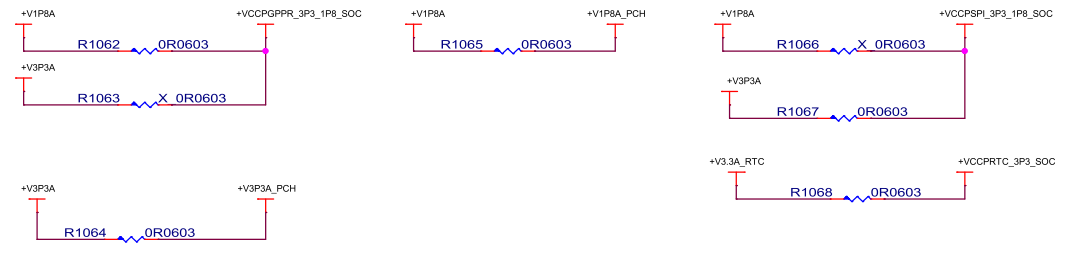

www.youyeetoo.com	
PROJ	<b>youyeetoo X1</b>
Title	SL SOC -CPU -PCH POWER
Size	Document Number
A3	11
Date:	Saturday, July 15, 2023
Sheet	11 of 39
Rev	A





EMC CAPS - PLACE <5MM FROM SOC VCCIN

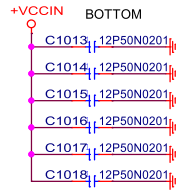

PLACE BOARD TOP SIDE

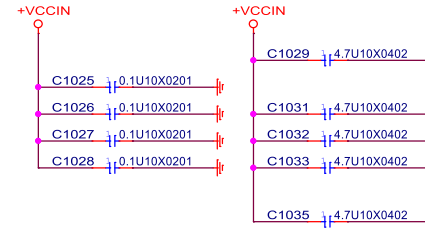
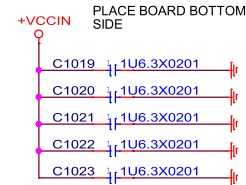
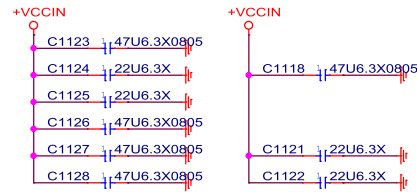

VCCSFR, VCCSTG, VCCST

TOP SIDE  
PI POR CAPS  
1 X 0402\_1UF  
+VCCST\_CPU

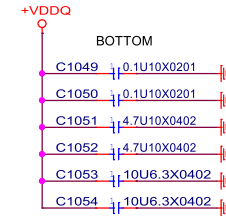
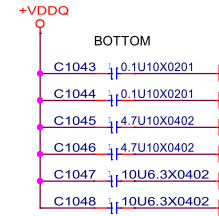
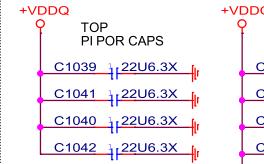
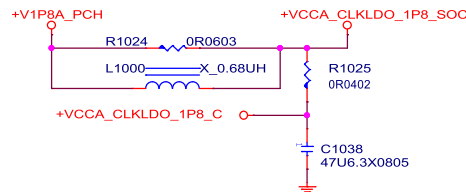
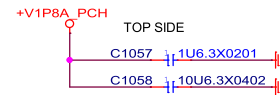
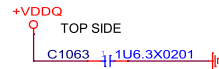
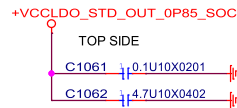
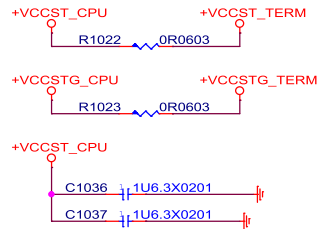

EMC CAPS - PLACE <4MM FROM SOC VDDQ, WITH EACH PAIR <12MM APART

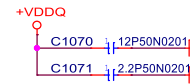
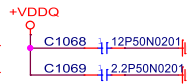
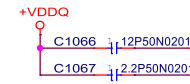
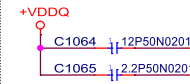

CPU CAP

PCH CAP

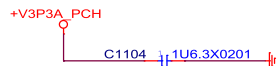
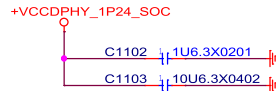
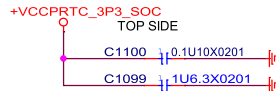
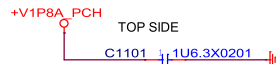
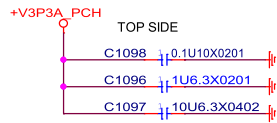

CAD NOTE:  
PLACE CAP C3F7 NEAR TO CK48 PIN OF SOC

EMC CAPS - PLACE <5MM FROM SOC VCCIN\_AUX

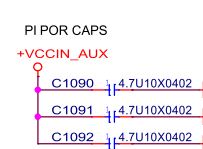
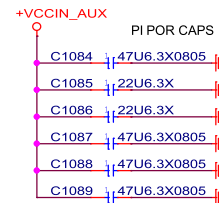
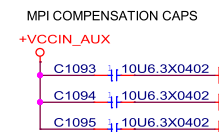
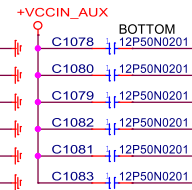
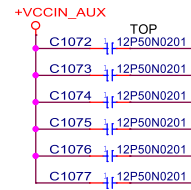

CAD NOTE:

PLACE RB AT THE END OF DAISY CHAIN

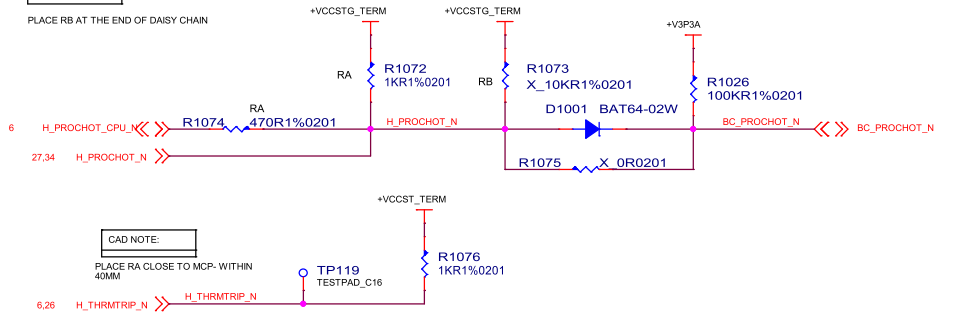

CAD NOTE:

PLACE RA CLOSE TO MCP- WITHIN 40MM

CAD NOTE:

PLACE R134 AND R54 CLOSE TO SOC- WITHIN 40MM

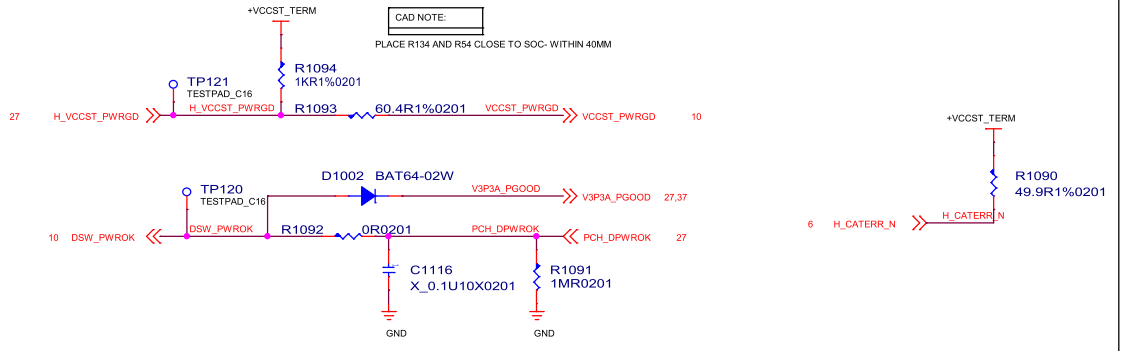

PAGE\_TITLE=CPU SIDE BANDS

PAGE\_TITLE=CPU SIDE BANDS

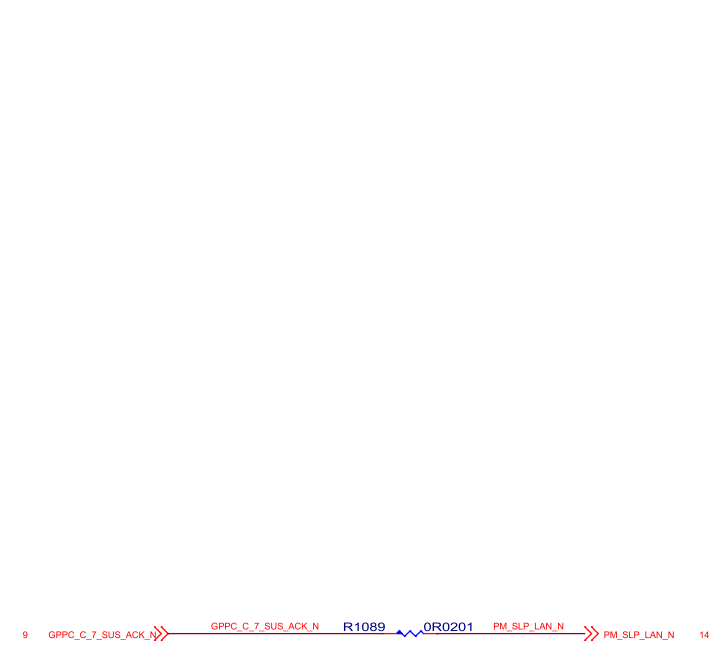
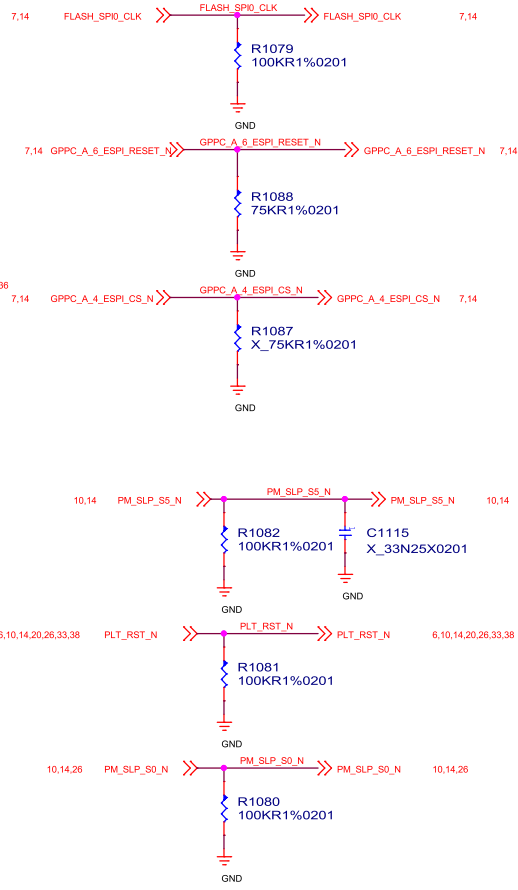
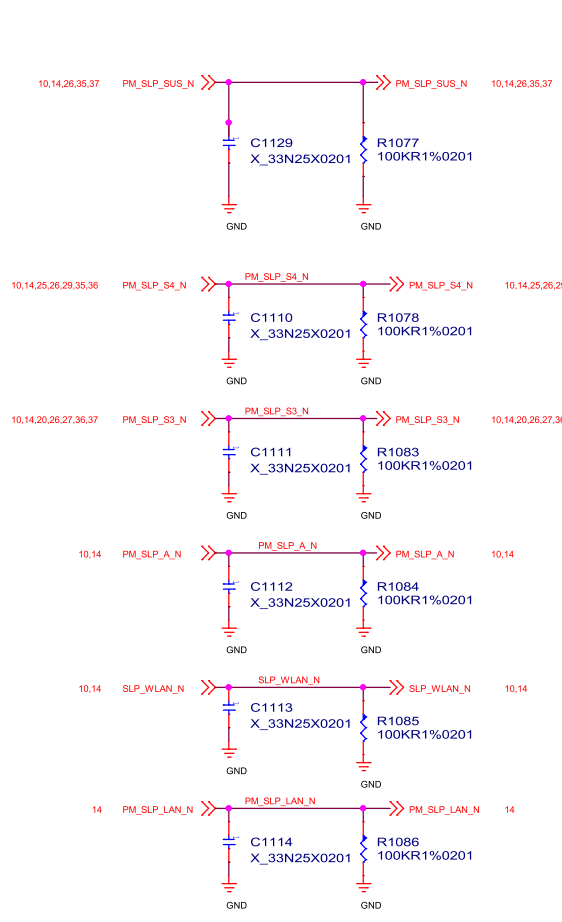

www.youyeetoo.com	
PROJ	<b>youyeetoo X1</b>
Title	JSL SIDE BANDS-PCH GLITCH MI
Size	Document Number
A3	14
Date:	Saturday, July 15, 2023
Sheet	14 of 39
Rev	A

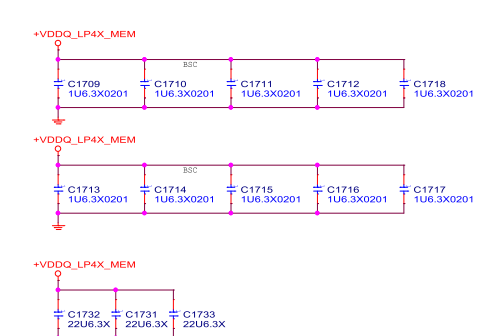
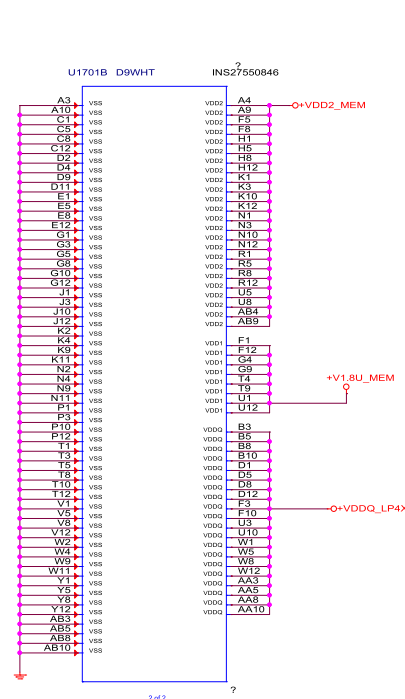
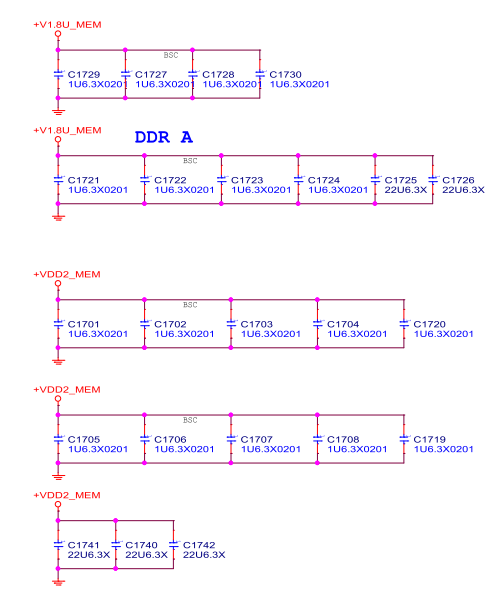
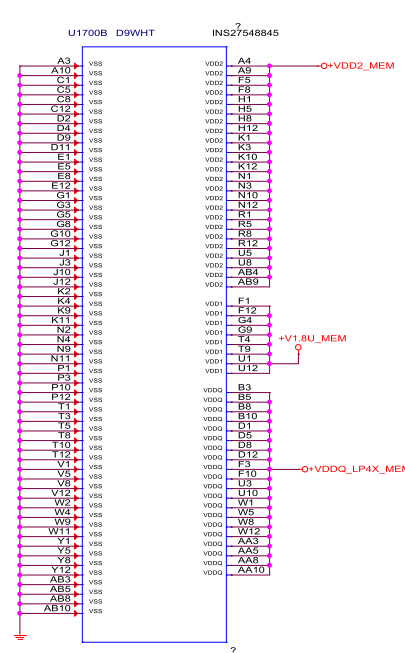
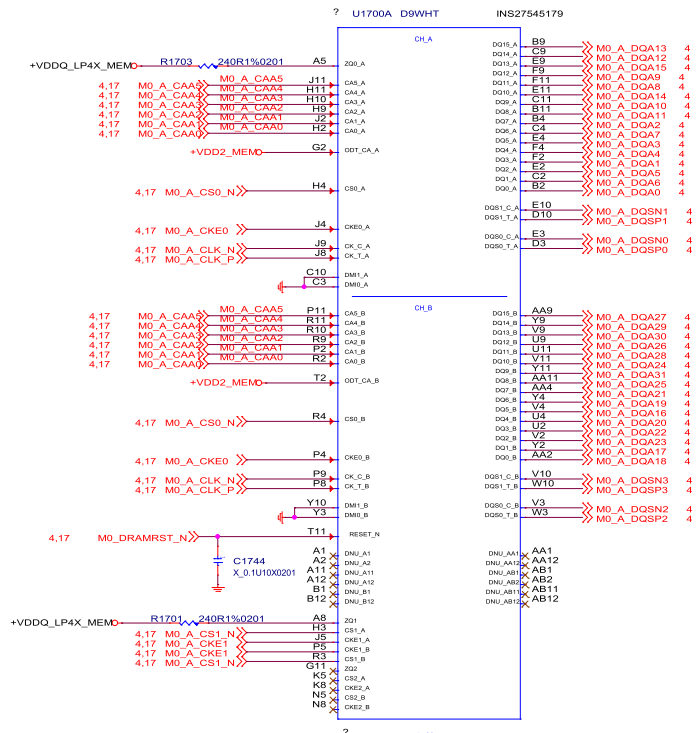

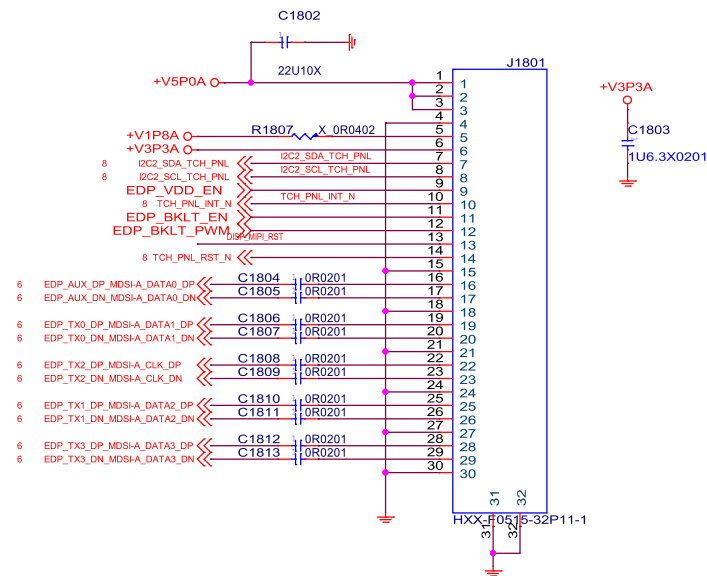
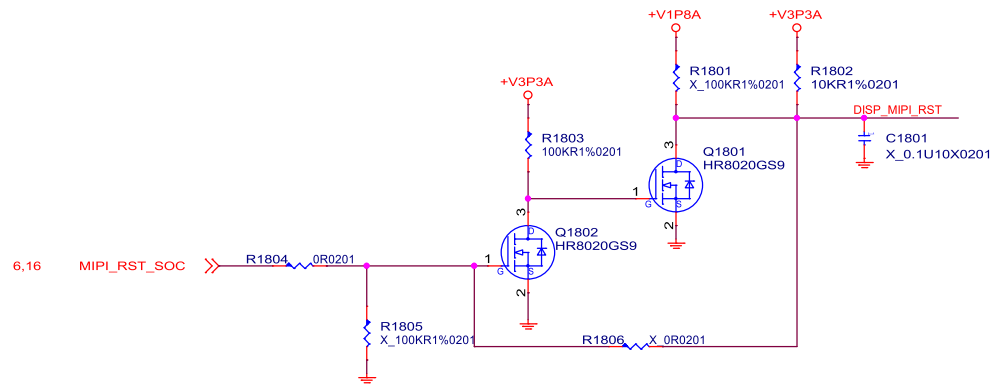

www.youyeetoo.com	
PROJ	youyeetoo X1
Title	LPDDR4x_376ball CHB
Size	Document Number
A3	18
Date:	Saturday, July 15, 2023
Sheet	18 of 39
Rev	A



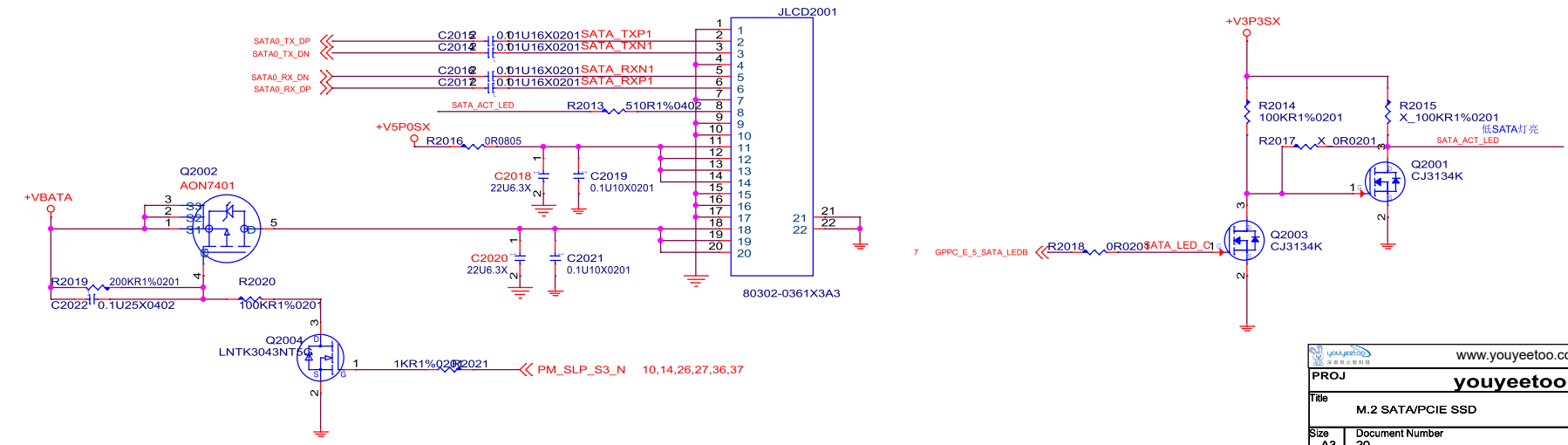
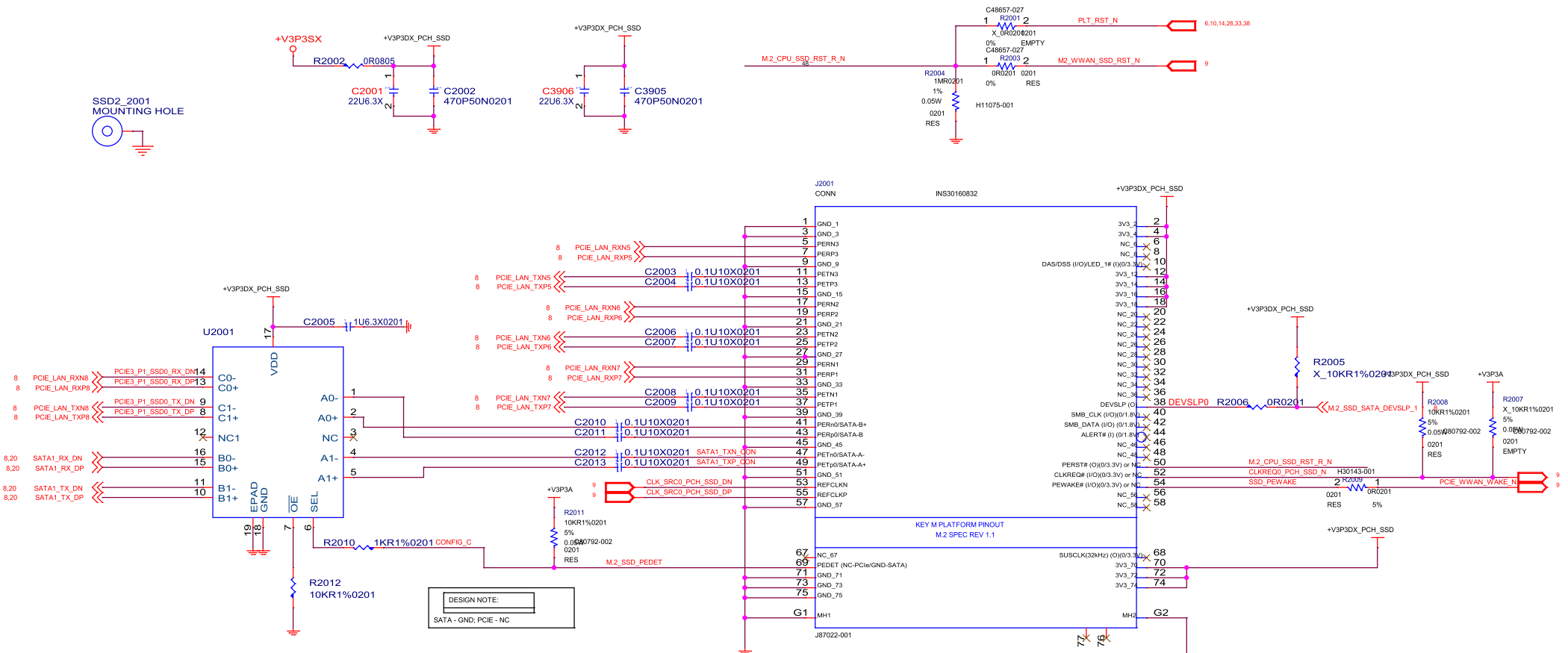

www.youyeetoo.com	
PROJ	<b>youyeetoo X1</b>
Title	M.2 SATA/PCIE SSD
Size A3	Document Number 20
Date:	Saturday, July 15, 2023
Sheet	20 of 39
Rev	A

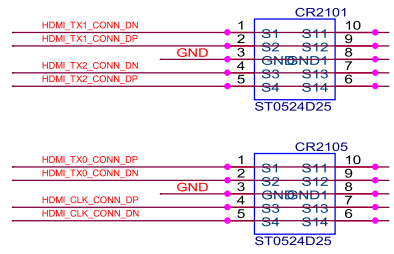
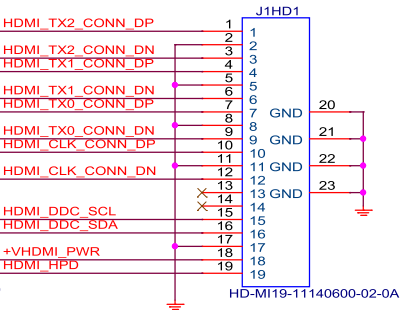
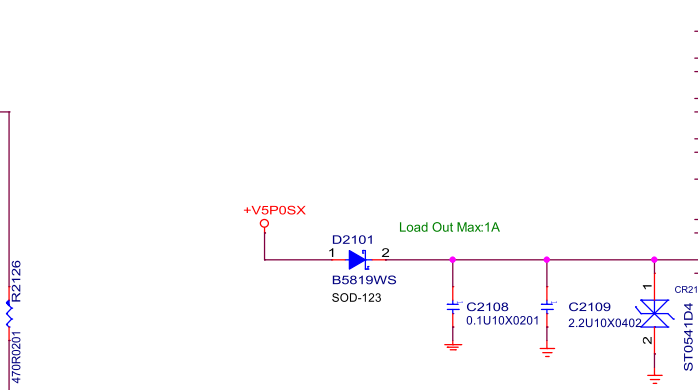
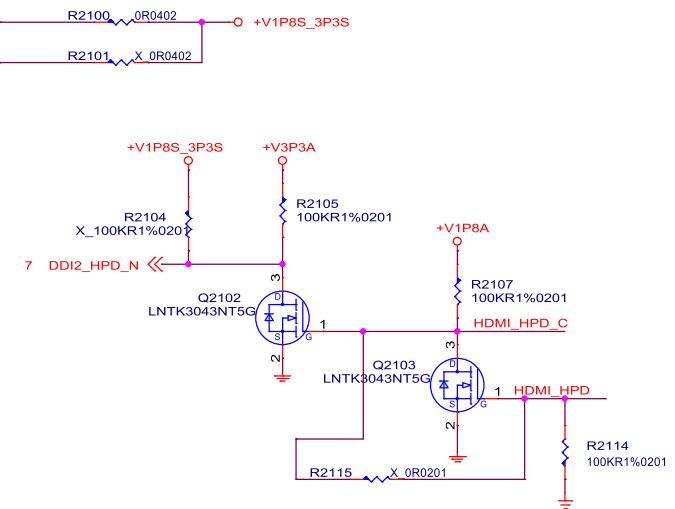
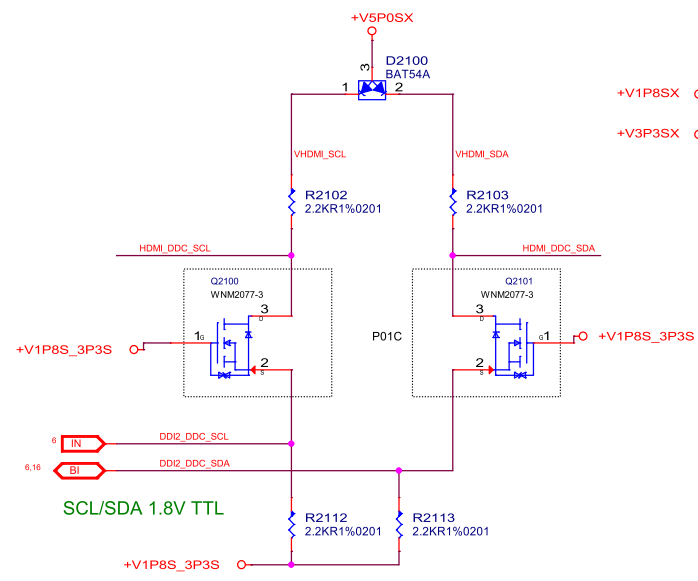
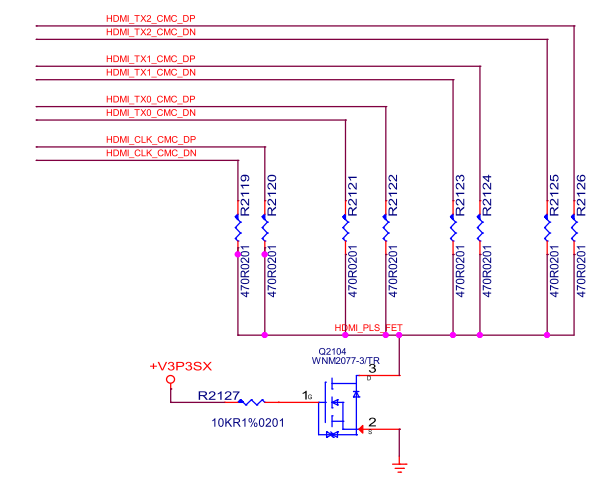
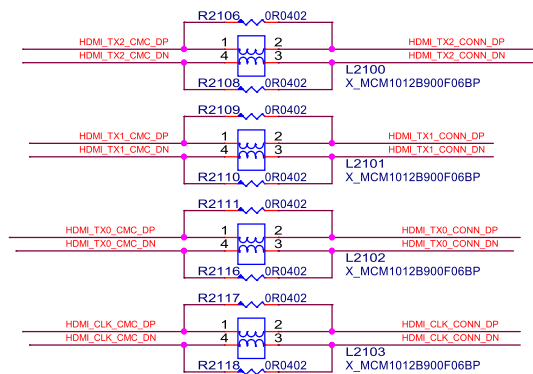
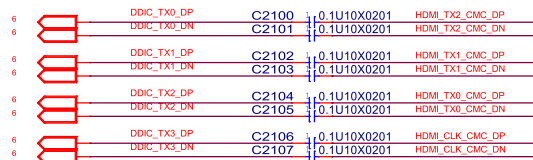

www.youyeetoo.com	
PROJ	<b>youyeetoo X1</b>
Title	HDMI A
Size A3	Document Number 21
Date:	Saturday, July 15, 2023
Sheet	21 of 39



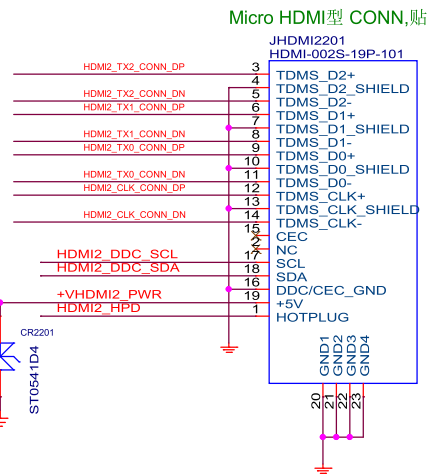
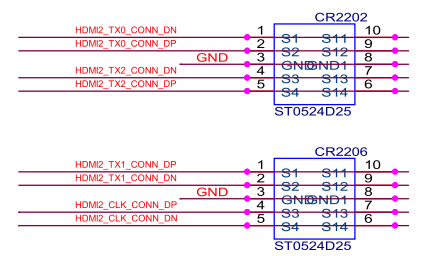
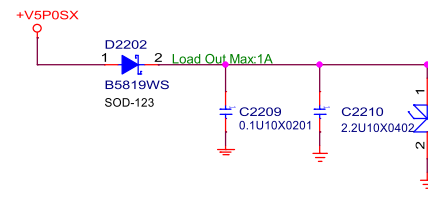
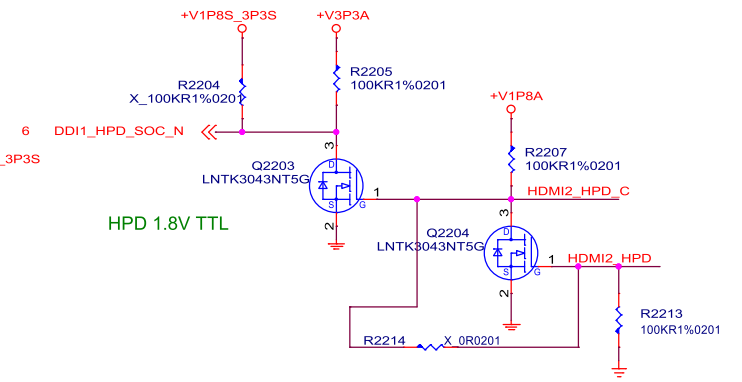
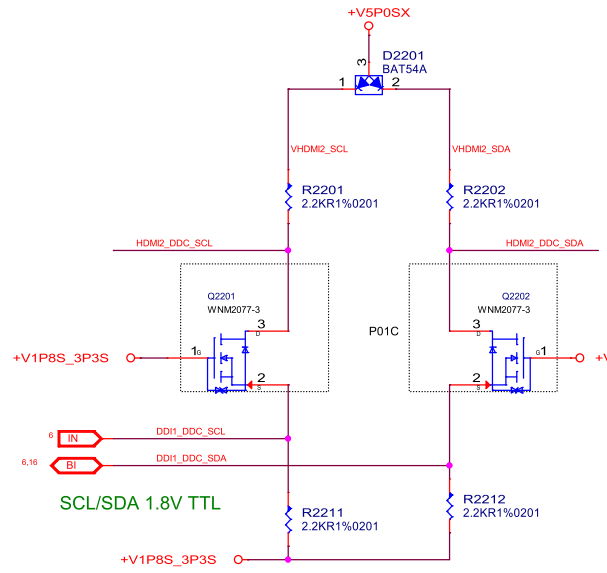
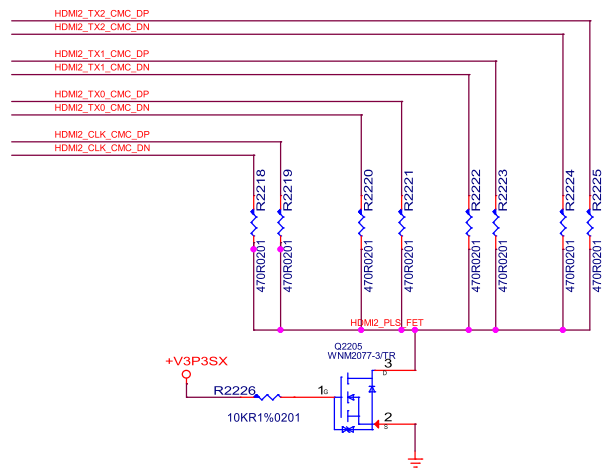
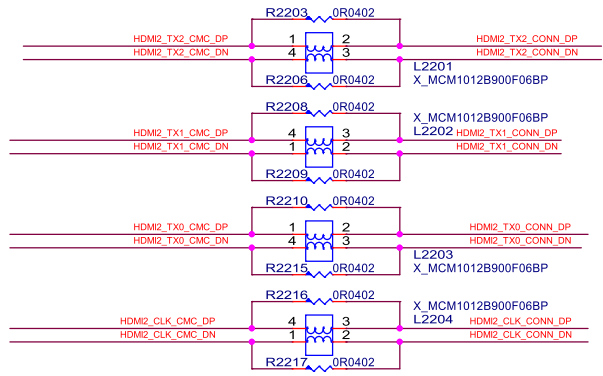
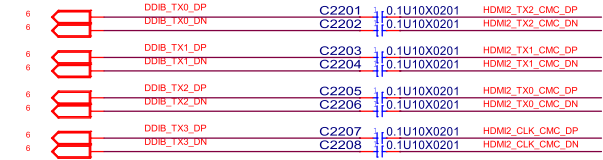

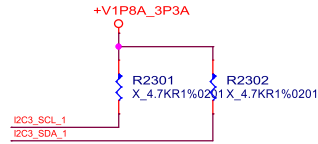

I2C接口

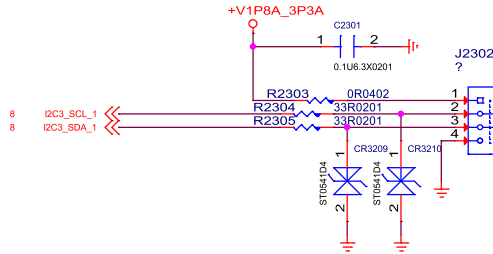

蓝色

UART1

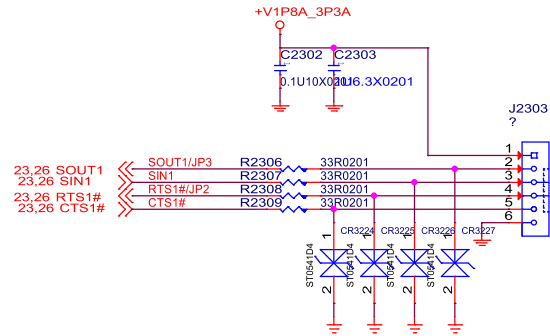

白色

SPI接口

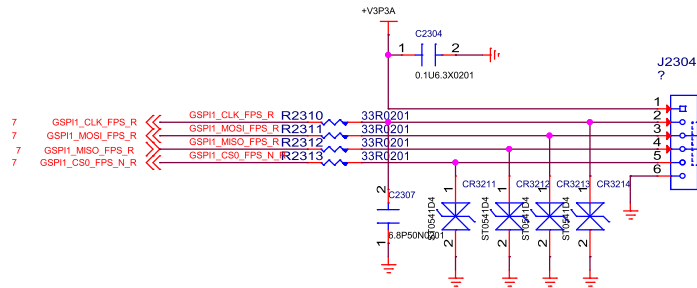

黄色

UART2

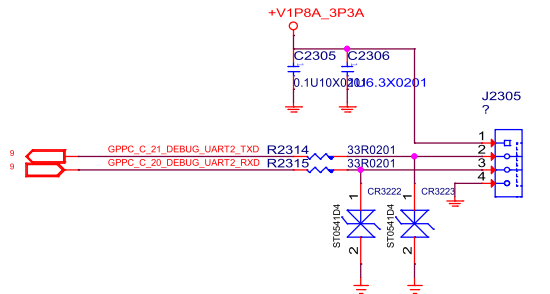

白色

GPIO接口

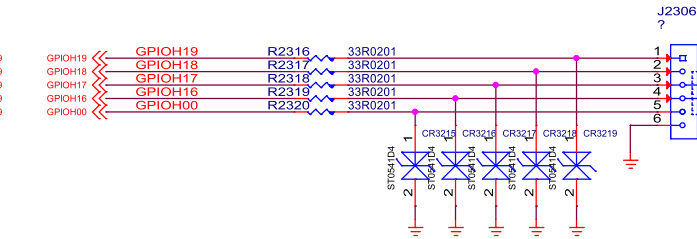

蓝色

UART3

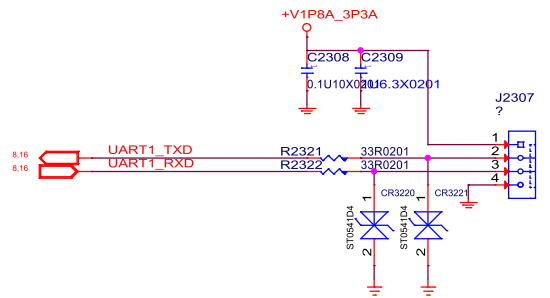

白色

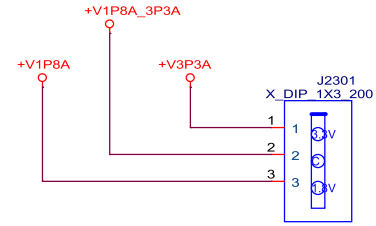
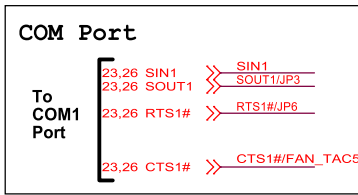

# USB2.0 TO SD Part

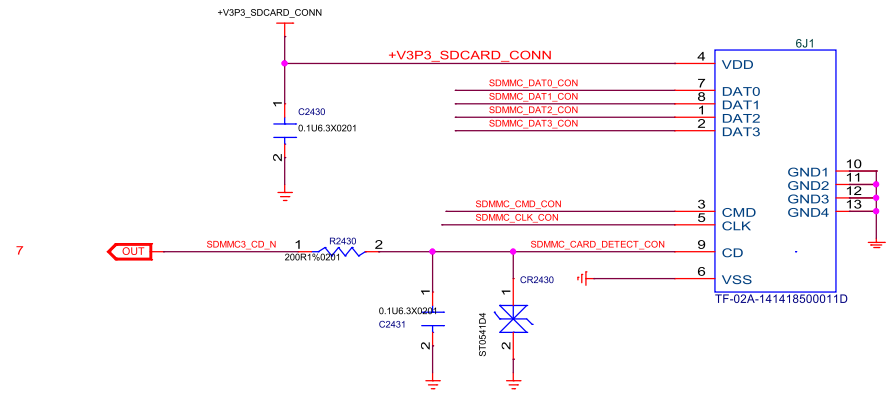
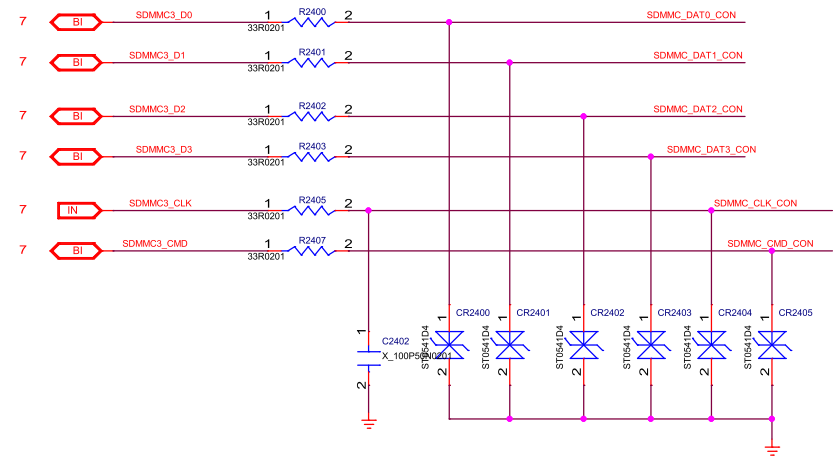
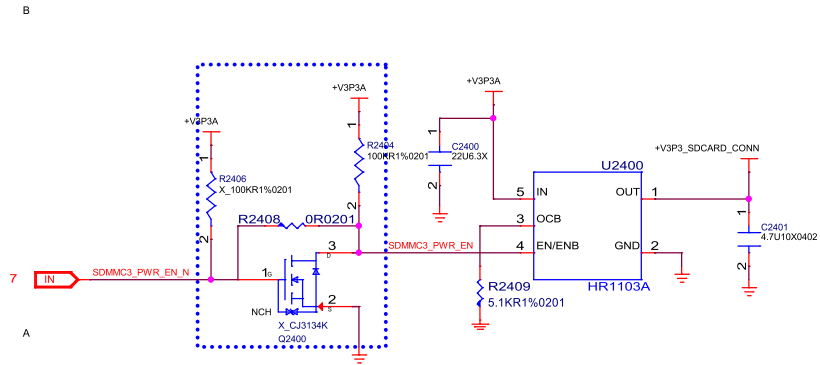

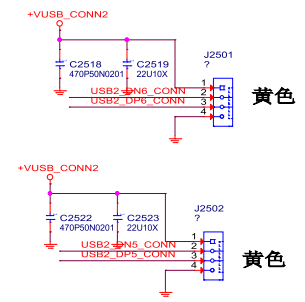
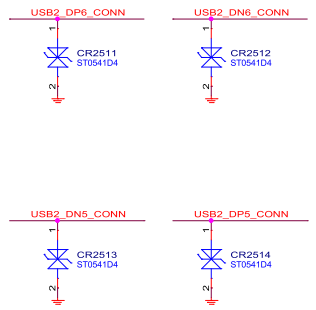
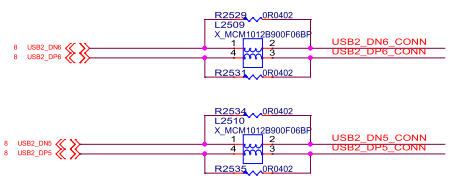
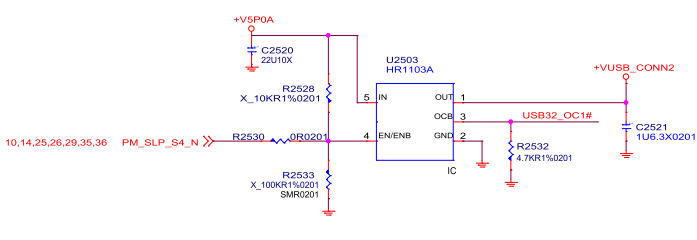
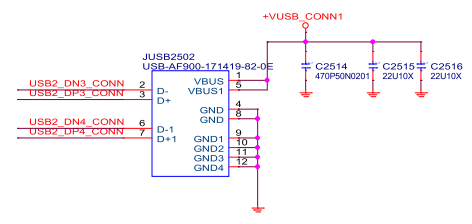
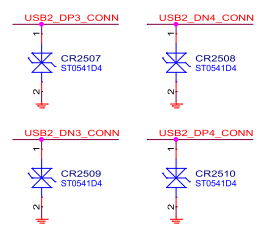
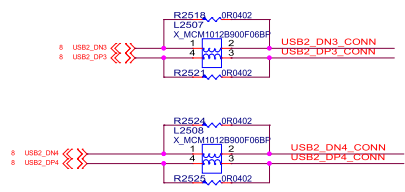
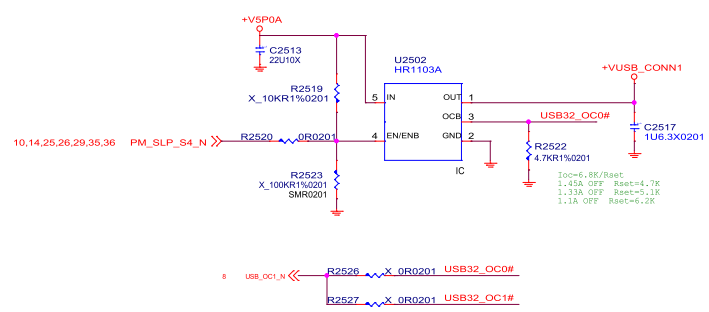
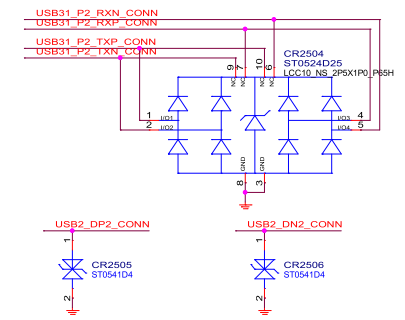
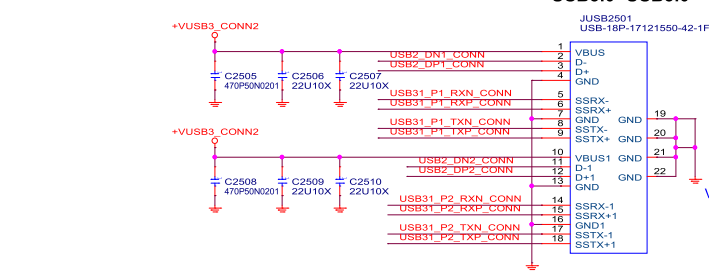
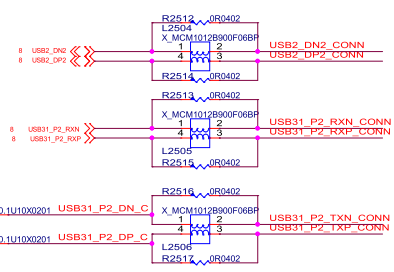
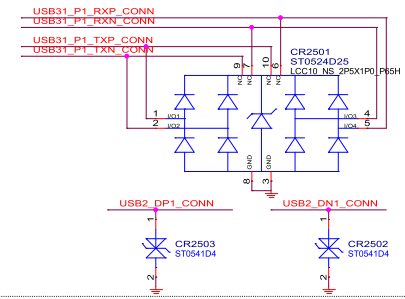
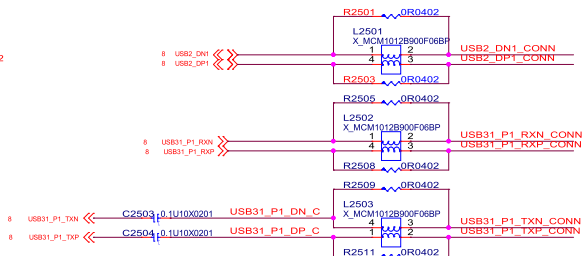
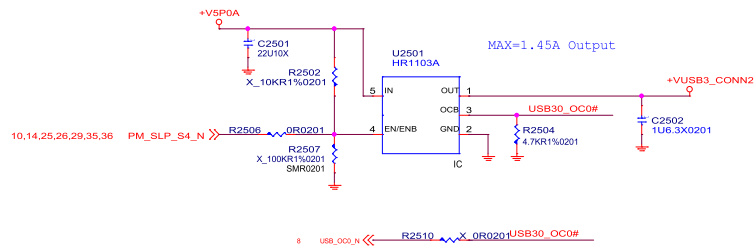

In DSW mode, SLP\_SUS can't floating  
 10,14,35,37 PM\_SLP\_SUS\_N >> R2609\_0R0201 SLP\_SUS#VLDT\_EN  
 6,14 H\_THRMTRIP\_N >> don't pull high THRMTRIP#PCH\_D0B#THRMTRIP#  
 12 H\_PECCI >> 0R0201\_R2610 PECCIAMDTSL\_C

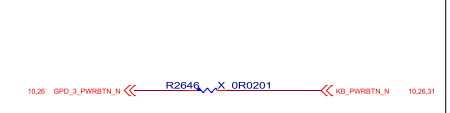
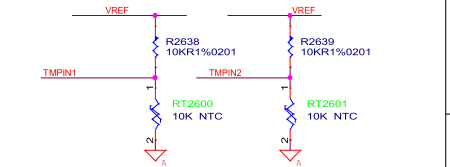
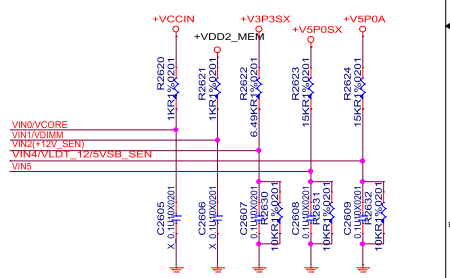
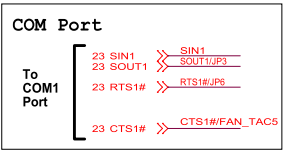
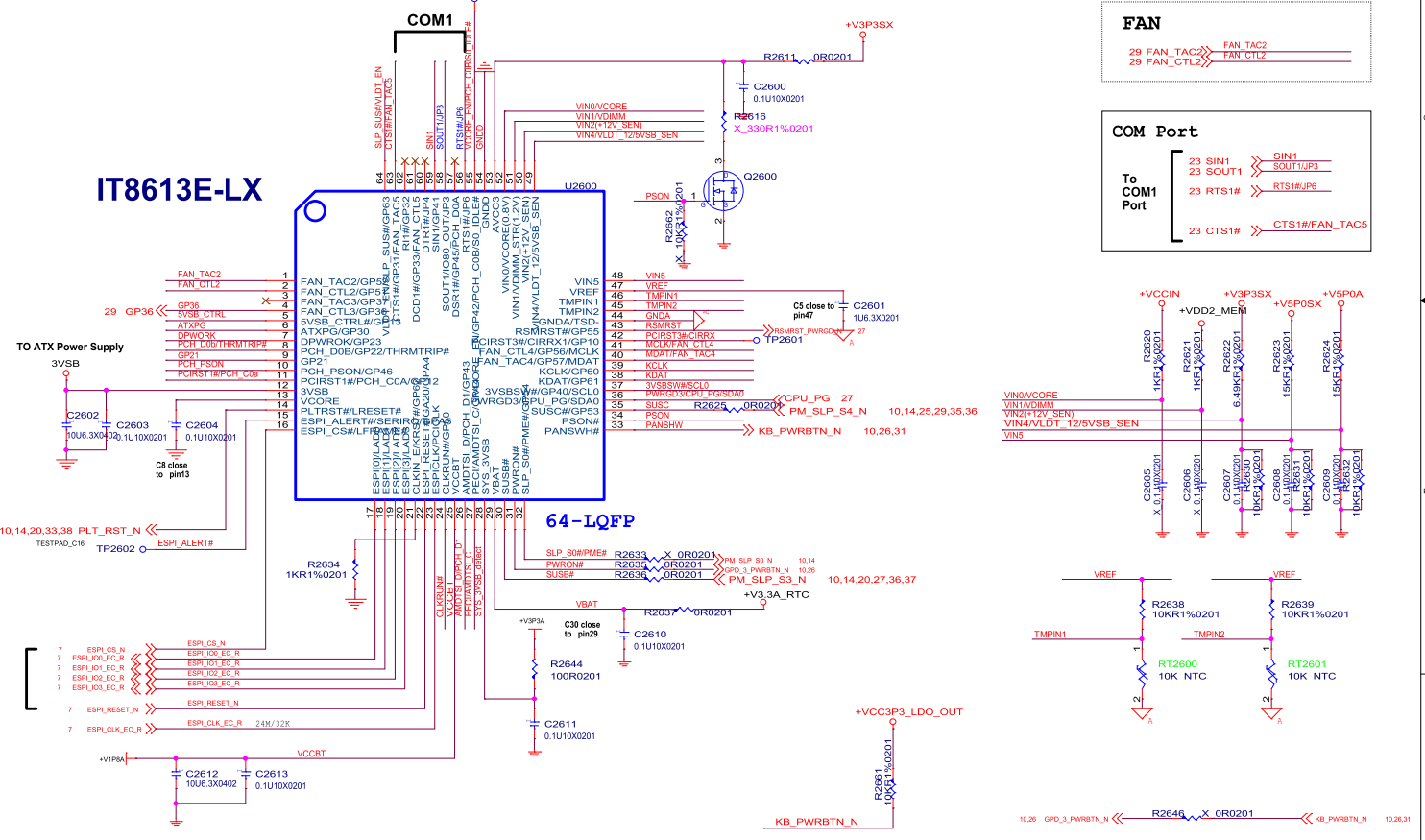
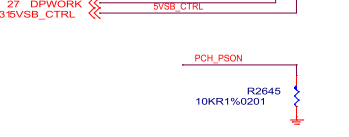
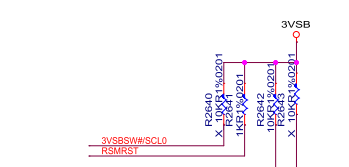
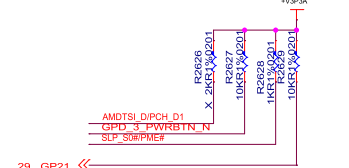
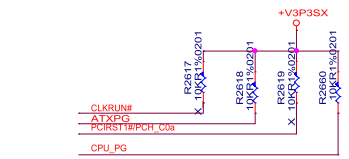
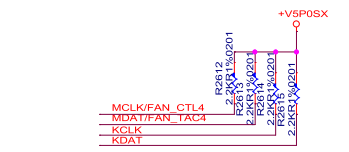
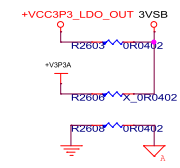



 www.youyeetoo.com		
PROJ	<b>youyeetoo X1</b>	
Title		
EC-2_PWR_NTC		
Size	Document Number	Rev
A2	28	A
Date: Saturday, July 15, 2023		Sheet 28 of 39

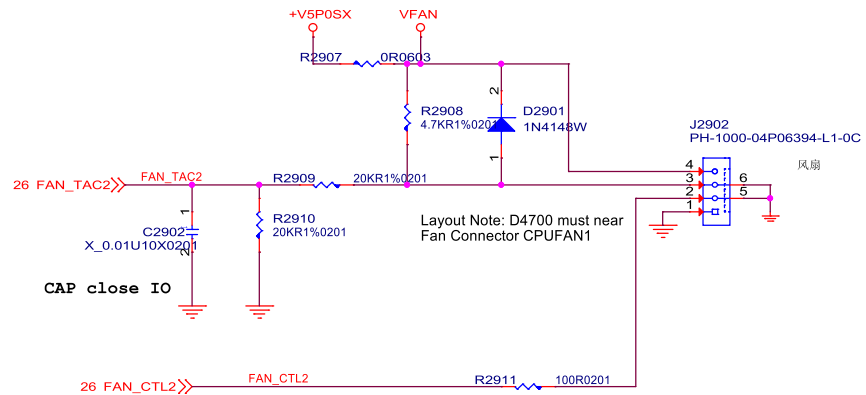
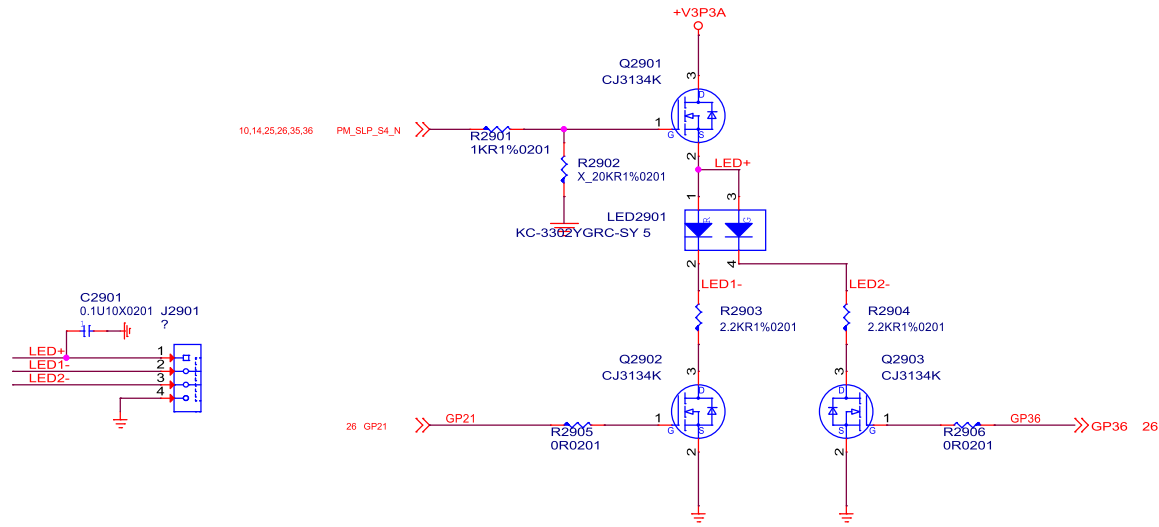

www.youyeetoo.com	
PROJ	<b>youyeetoo X1</b>
Title	EC-3_LED_FAN
Size	Document Number
A3	29
Date:	Saturday, July 15, 2023
Sheet	29 of 39
Rev	A

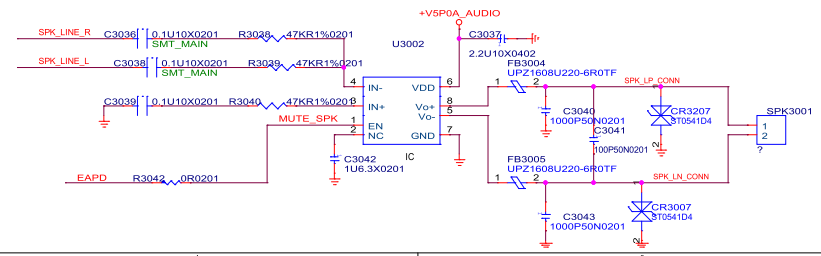
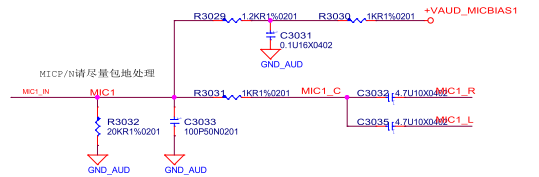
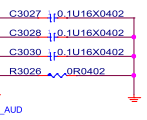
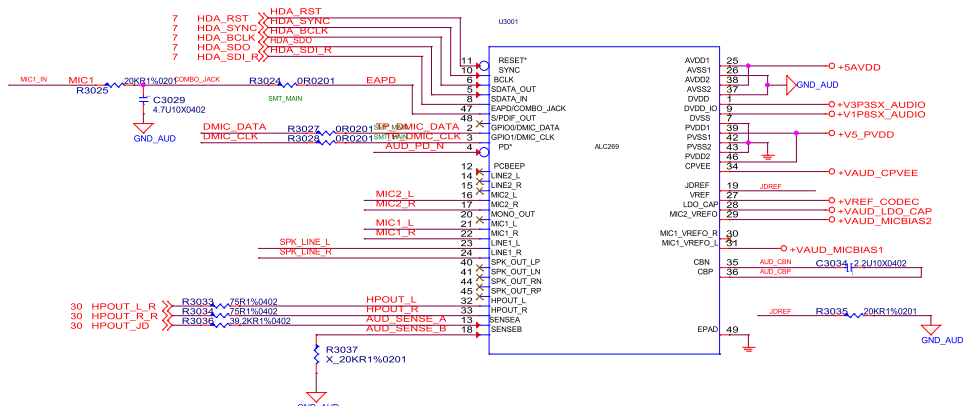
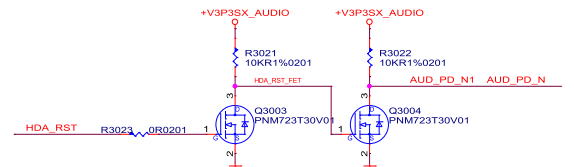
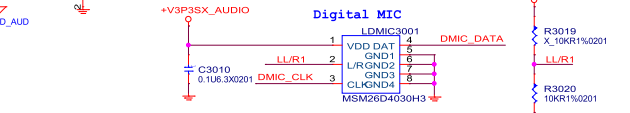
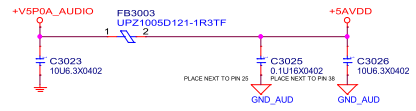
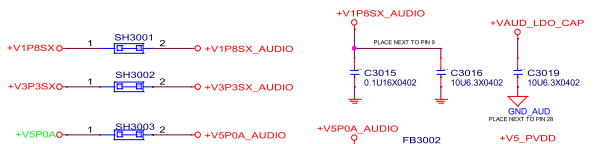
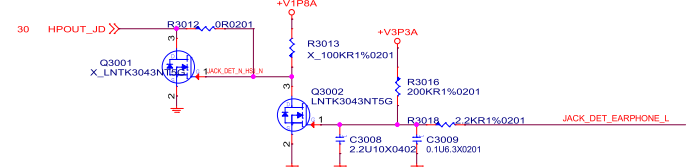
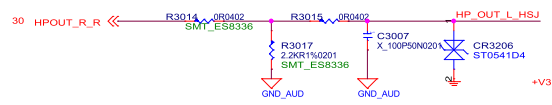
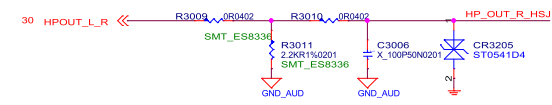
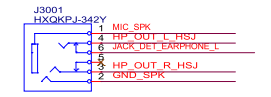
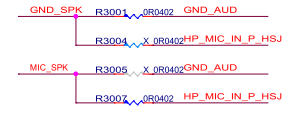
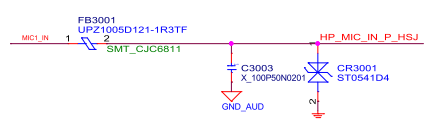
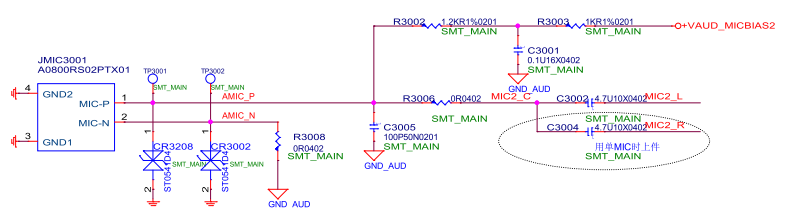



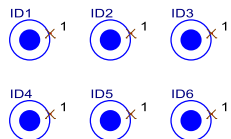
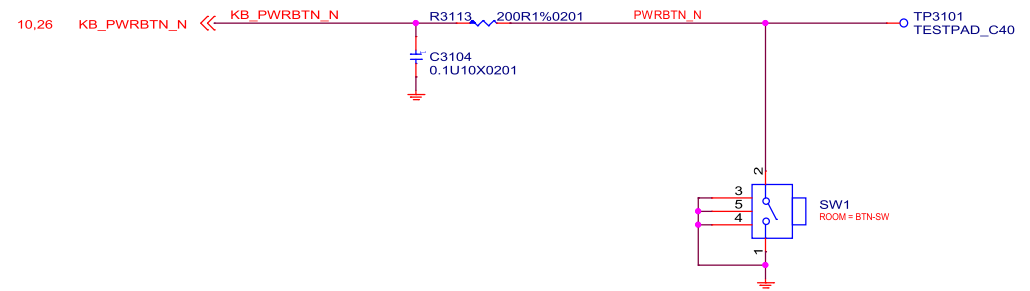
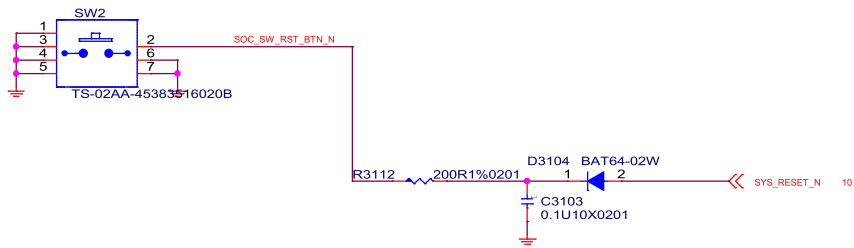
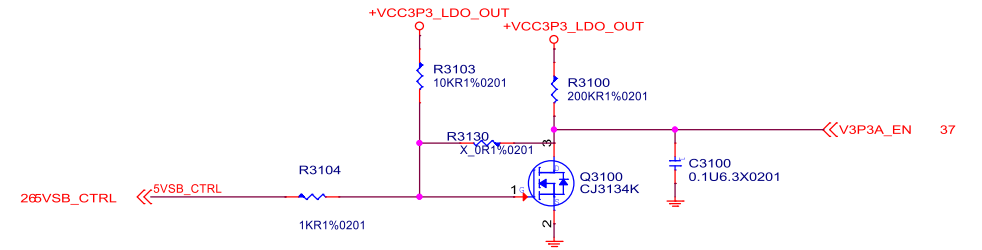

散热片铜螺柱



www.youyeetoo.com	
PROJ	<b>youyeetoo X1</b>
Title	POWER BUTTON_MARK
Size	Document Number
A3	31
Date:	Saturday, July 15, 2023
Sheet	31 of 39
Rev	A

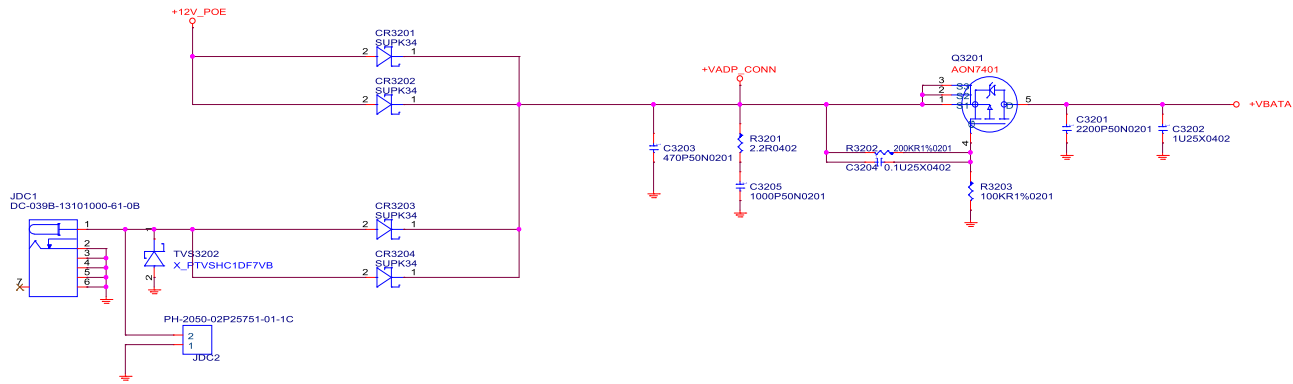

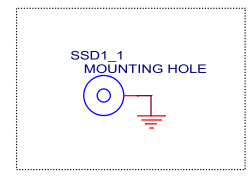
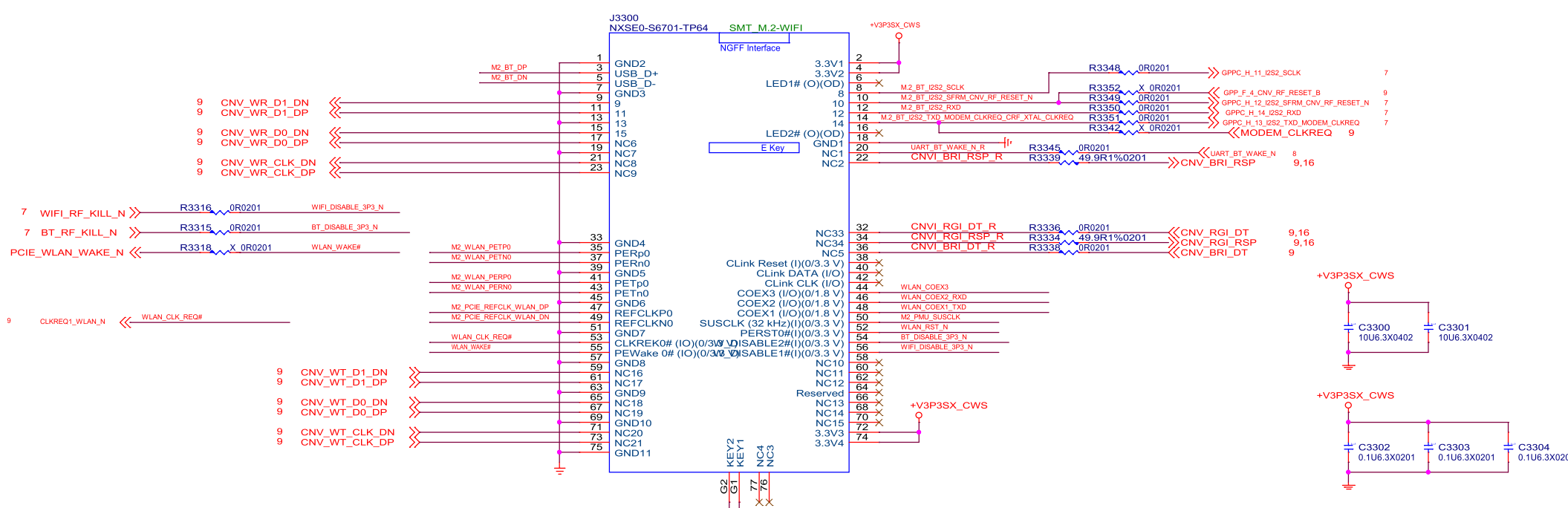
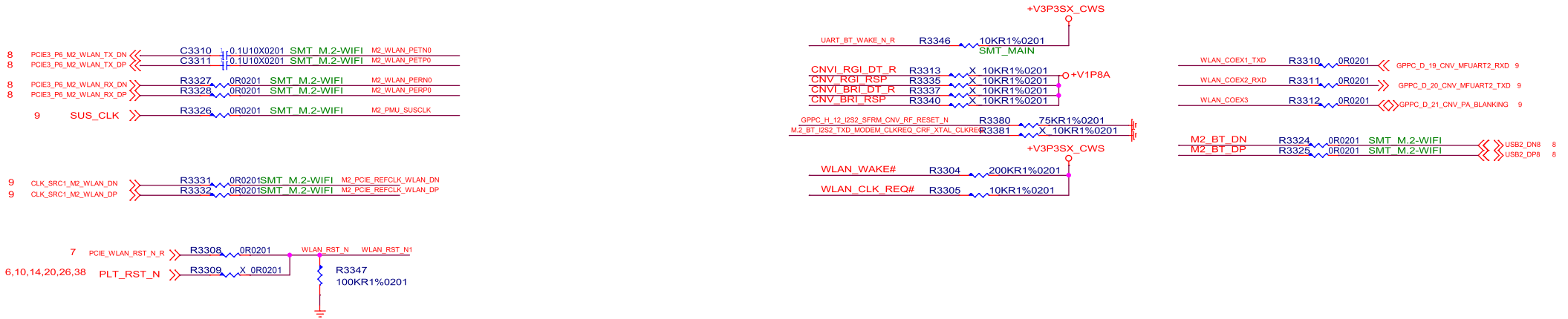

www.youyeetoo.com	
PROJ	<b>youyeetoo X1</b>
Title	WLAN_7265_9461_9560_M.2 WIFI
Size A3	Document Number 33
Date:	Saturday, July 15, 2023
Sheet	33 of 39
Rev	A

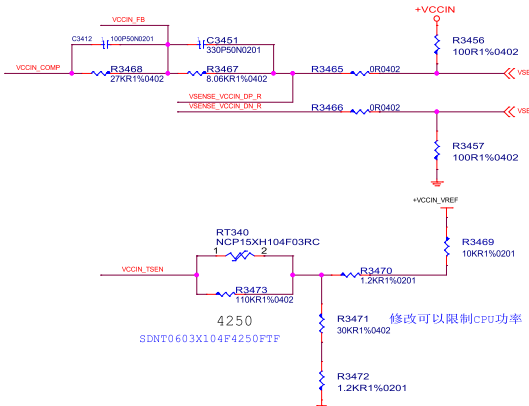
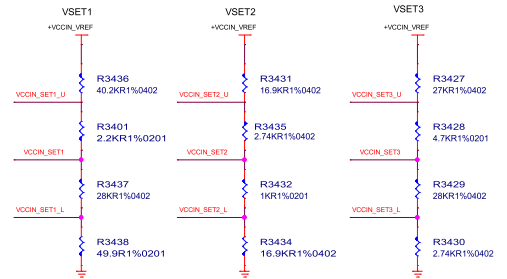
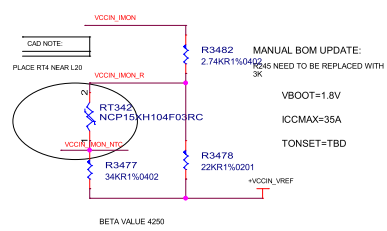
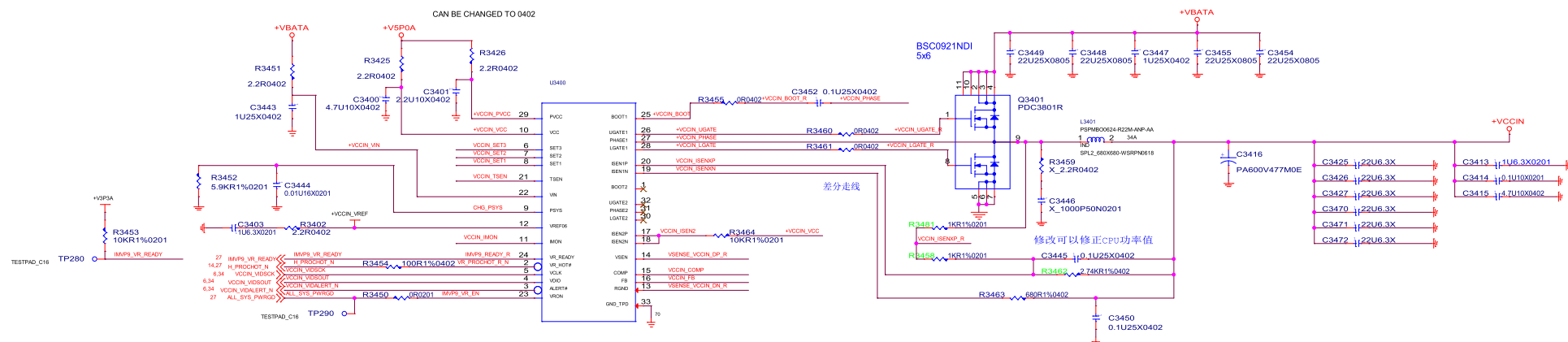
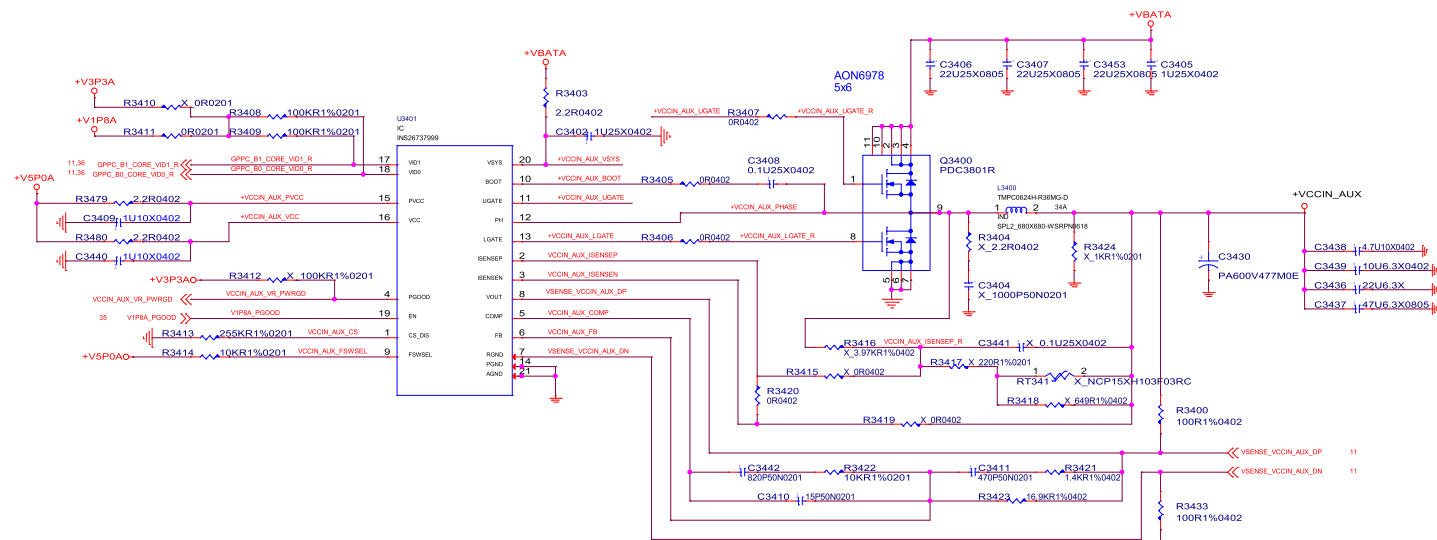



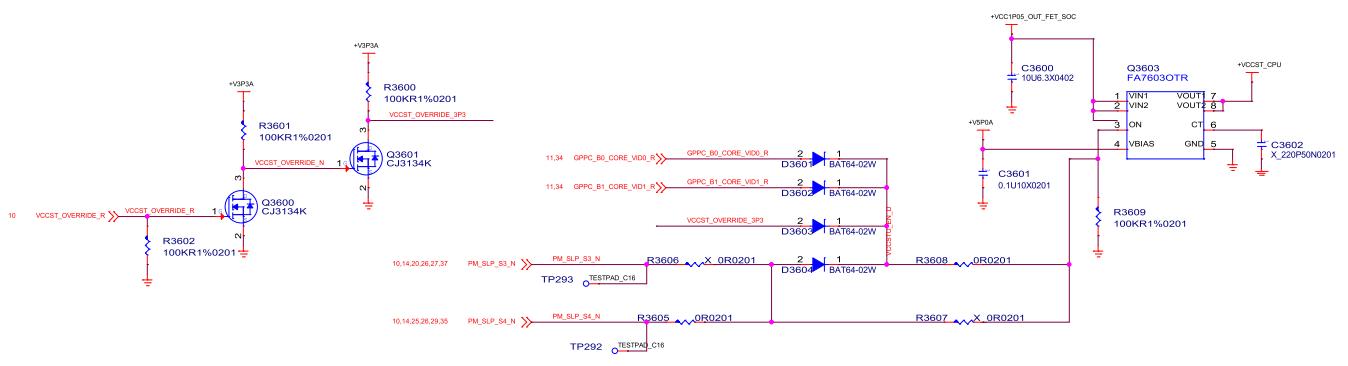

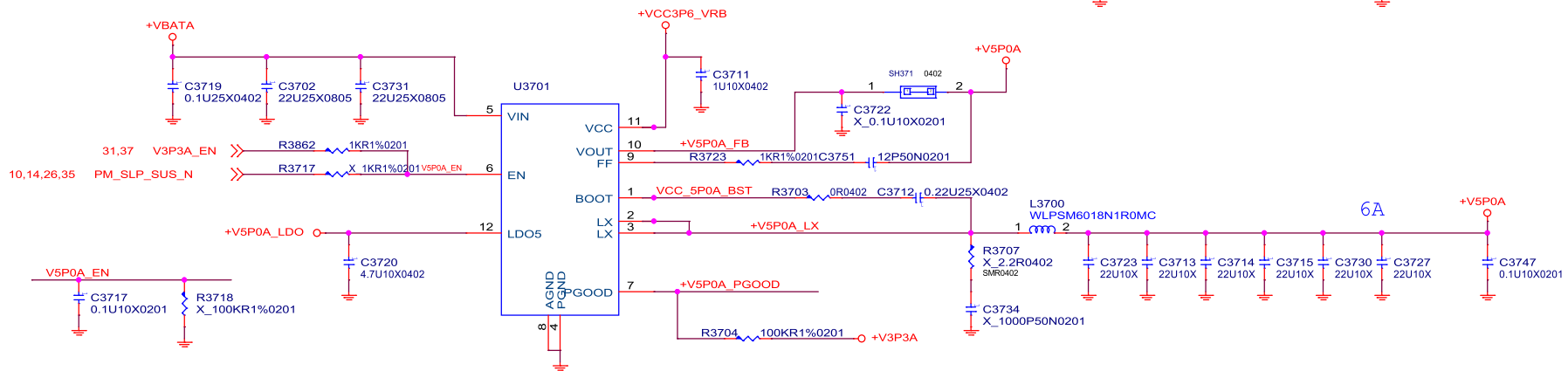
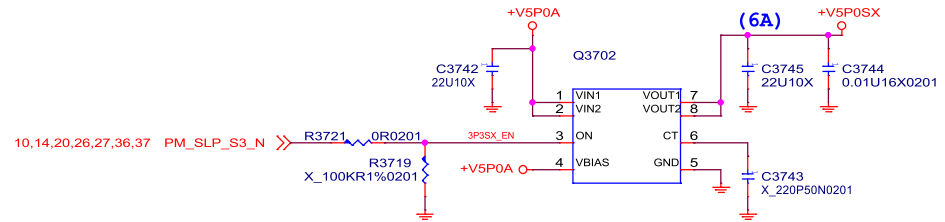
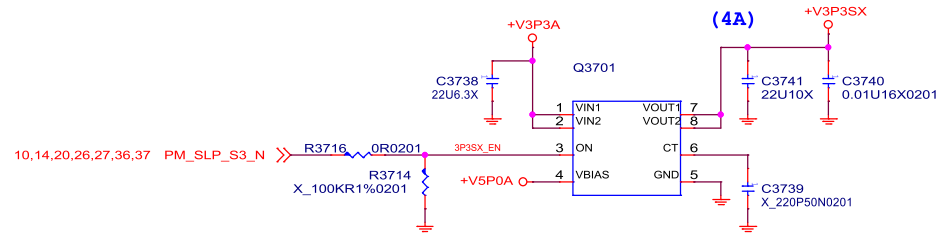
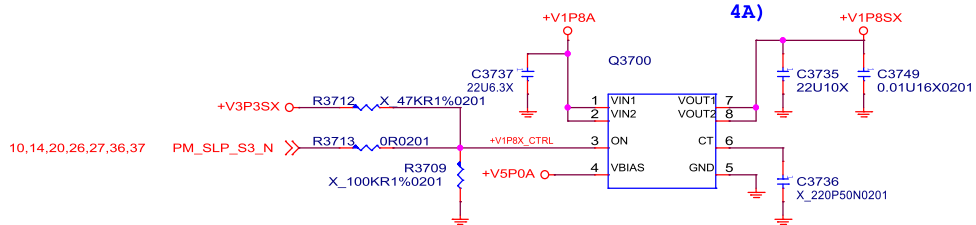
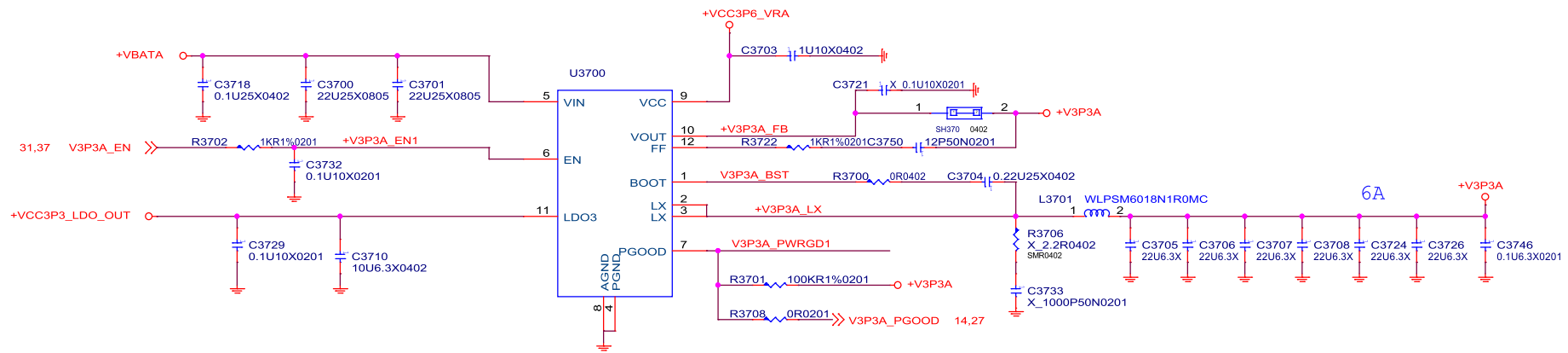

www.youyeetoo.com	
PROJ	<b>youyeetoo X1</b>
Title	PWR 3.3VA_5VA_S3-PWR
Size	Document Number
A3	37
Date:	Saturday, July 15, 2023
Sheet	37 of 39
Rev	A

# Controller

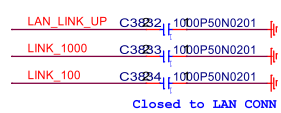
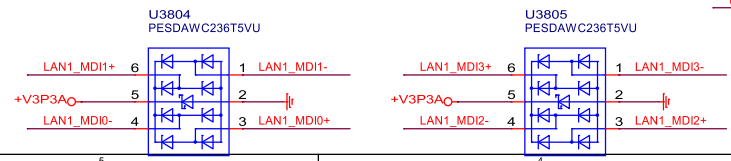
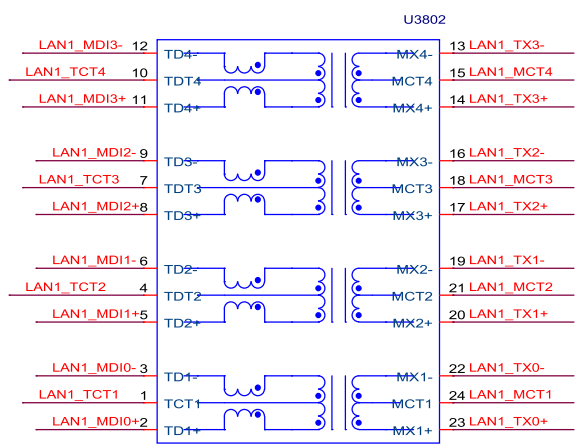
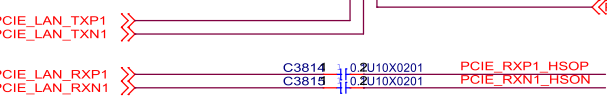
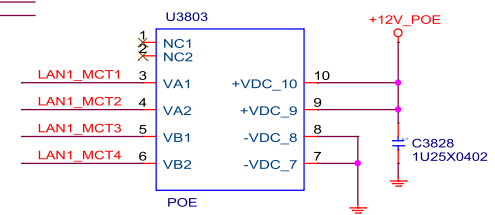
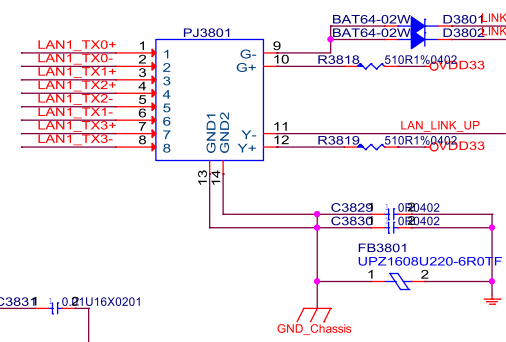
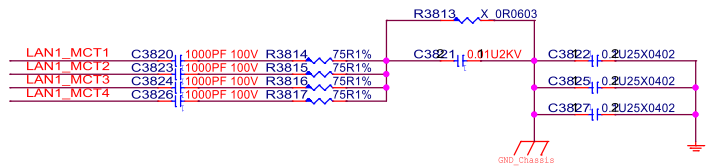
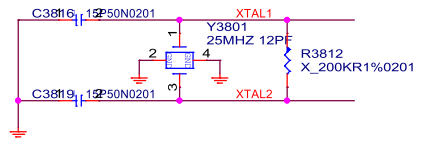
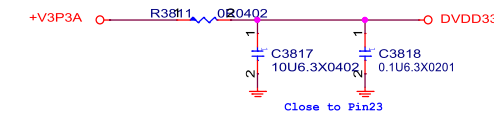
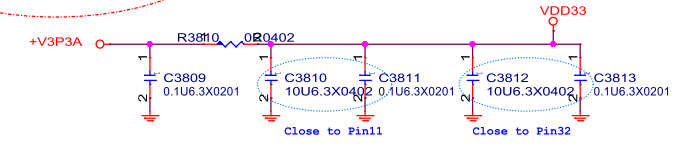
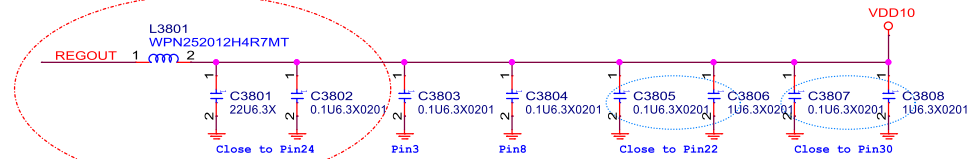
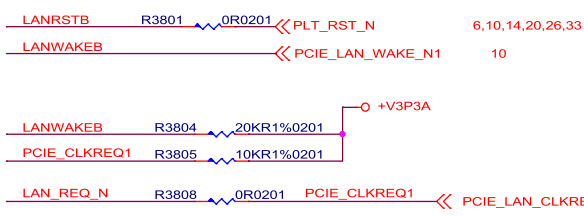
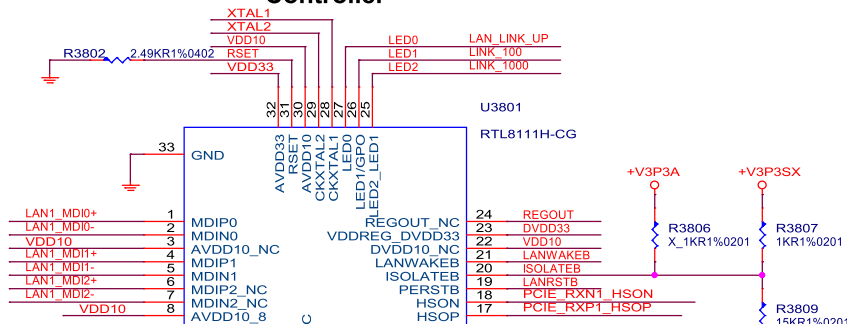

www.youyeetoo.com	
PROJ	youyeetoo X1
Title	PCIE LAN I225-LM
Size A3	Document Number 26
Date: Saturday, July 15, 2023	Sheet 38 of 39



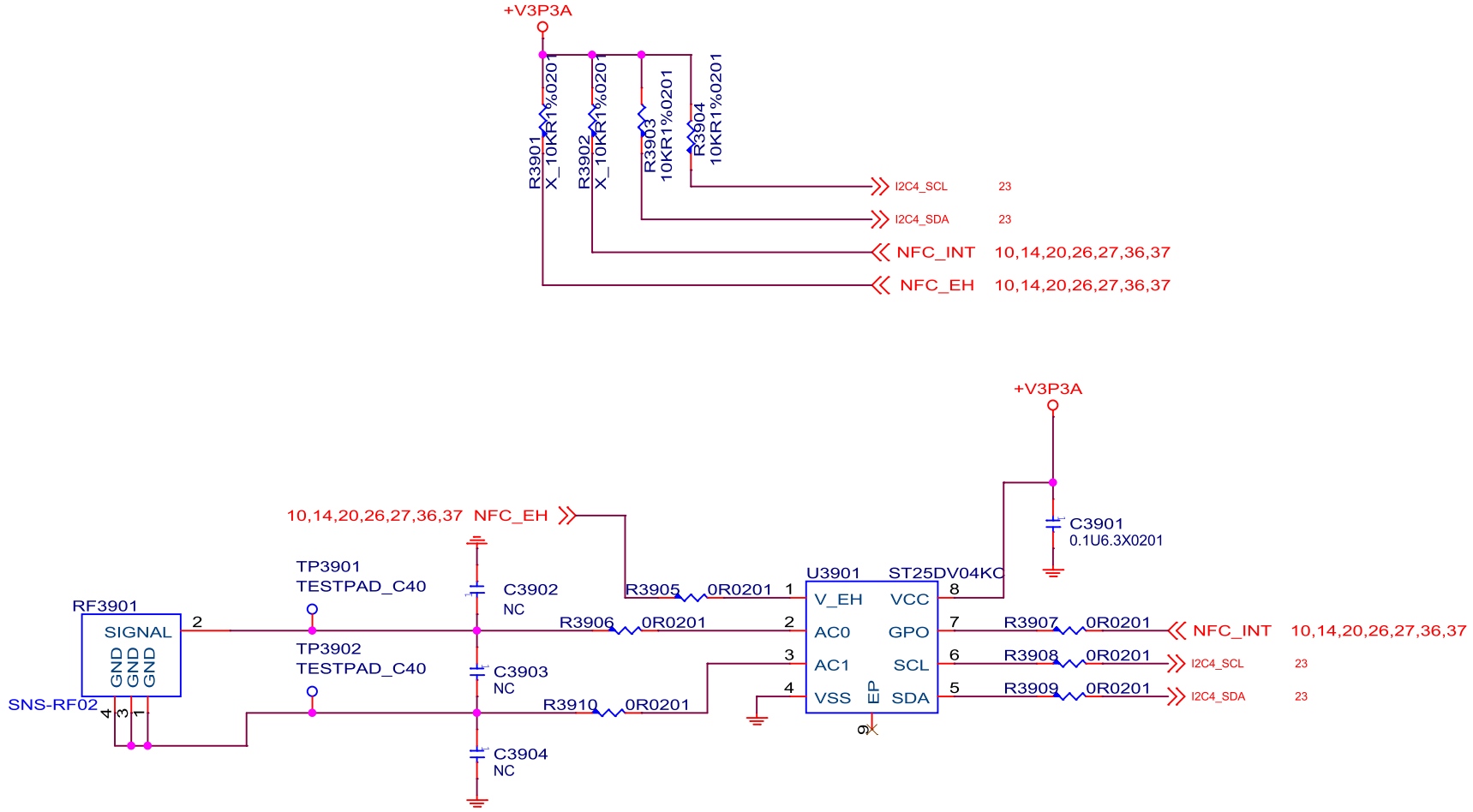

		www.youyeetoo.com	
<b>PROJ</b>		<b>youyeetoo X1</b>	
Title PCIE LAN I225-LM			
Size A4	Document Number 26		Rev A
Date:	Saturday, July 15, 2023	Sheet	39 of 39